

OL/2009/34/E-I

ලියවුම් හිමිකම් ඇවිරිණි]

முழுப் பதிப்புரிமையுடையது]

All Rights Reserved]

ශ්‍රී ලංකා විභාග දෙපාර්තමේන්තුව
 Department of Examinations, Sri Lanka
 ශ්‍රී ලංකා විභාග දෙපාර්තමේන්තුව
 Department of Examinations, Sri Lanka
 Department of Examinations, Sri Lanka
 Department of Examinations, Sri Lanka

34 E I

අධ්‍යයන පොදු සහතික පත්‍ර (සාමාන්‍ය පෙළ) විභාගය, 2009 දෙසැම්බර්
 සේවිථි පොදුභිත ත්‍රාතරප් පත්තිර (ඡාතාරණ ත්‍රා)ප් පරීඨඡෂ, 2009 අ.ඡෂෂපර
 General Certificate of Education (Ord. Level) Examination, December 2009

විඨෂාඡ **I**
 බිඡුඡුඡාණඡ **I**
 Science **I**

පැය ඡකටී
 ඡුඡු ඡඡඡඡඡඡඡඡඡඡ
 One hour

Note: (i) Answer all questions.

(ii) In each of the questions 1 to 40, pick one of the alternatives (1), (2), (3), (4) which you consider is correct or most appropriate.

(iii) Mark a cross (X) on the number corresponding to your choice in the answer sheet provided.

(iv) Further instructions are given on the back of the answer sheet. Follow them carefully.

- Another feature that can be seen in an organism having a soft unsegmented body, covered by a calcium carbonate shell is
 - the presence of jointed limbs.
 - living only on land.
 - the presence of suckers at the two ends of the body.
 - the presence of a muscular foot.
- Which feature given below differentiates algae from fungi?
 - Presence of a thallus like body
 - Ability to photosynthesize
 - Presence of well organised nuclei
 - Production of spores for reproduction
- Seeds that are dispersed by water, wind and animals are respectively,
 - Indian almond (*kottamba*), drumstick, (*muringa*), cashew (*cadju*).
 - water lily, *apala*, cotton.
 - coconut, rubber, mango.
 - calotropis (*vara*), orchid, love grass (*thuththiri*).
- Select the response that gives the correct scientific name of the shoe flower plant.
 - Hibiscus Rosasinensis
 - Hibiscus rosasinensis*
 - HIBISCUS ROSASINENSIS
 - Hibiscus Rosasinensis*
- A type of multinuclear cell is, the
 - epithelial cell.
 - smooth muscle cell.
 - white blood cell.
 - skeletal muscle cell.
- Which one out of the following factors essential for photosynthesis, cannot be tested experimentally in the laboratory by a student studying about photosynthesis?
 - Light
 - Water
 - Chlorophyll
 - Carbondioxide
- The graph given below illustrates the growth of a population. What is the stage at which competition among organisms is at a minimum?
 - 1st stage
 - 2nd stage
 - 3rd stage
 - 4th stage
- Select the correct statement out of those given below regarding visual defects.
 - Short sightedness is the situation where objects at a distance can be seen clearly whereas objects that are close cannot be seen clearly.
 - Long sightedness can be corrected by wearing spectacles with suitable concave lenses.
 - Everything around is seen in black and white by persons suffering from total colour blindness.
 - Long sightedness and short sightedness are inherited defects.
- Urea and uric acid which are the main nitrogenous excretory products of man are produced in the
 - kidney.
 - liver.
 - pancreas.
 - nephrons.
- An ailing condition caused by a sex linked recessive gene is
 - allelism.
 - haemophilia.
 - thalassaemia.
 - sickle cell anemia.

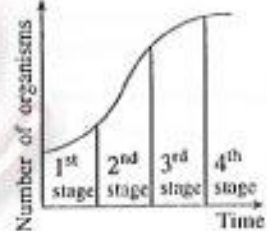

11. A group of animals with long horns living in a jungle with thorny shrubs, could not run fast, as a result of which they became prey to predators and gradually got destroyed. This reflects,
- (1) struggle for existence. (2) over production.
(3) survival of the fittest. (4) selection.

● The question numbers 12 and 13 are based on the following description.

A cross between a homozygous organism and a heterozygous organism is illustrated here. R is the dominant character, while r is the recessive character.

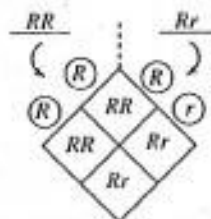

12. The genotype ratio of the F_1 generation is
(1) 1 : 1 (2) 1 : 2 : 1
(3) 3 : 1 (4) all belong to the same genotype.
13. The phenotype ratio of the F_1 generation is
(1) 1 : 1 (2) 1 : 2 : 1
(3) 3 : 1 (4) all belong to the same phenotype.

14. Equal volumes of the two liquids A and B, which are equal in polar properties, and which do not react with each other are added to a test tube. What is the most possible way, the two liquids A and B could exist in the test tube?

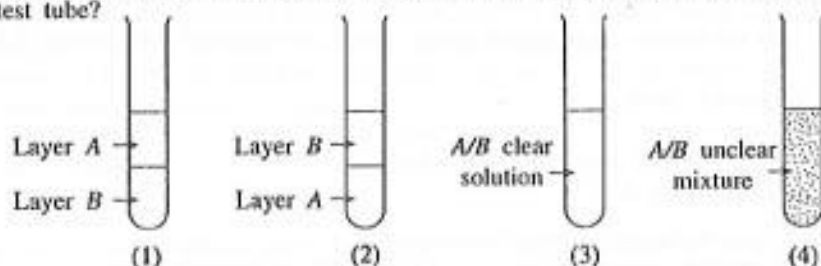

15. The diagram illustrates how the electrons are arranged in the outer most shell of the element A. Select the most correct statement regarding element A.

- (1) A is an element belonging to the second period of the Periodic Table.
(2) A is an element belonging to the Group V of the Periodic Table.
(3) Two atoms of A will share three pairs of electrons and form A_2 molecules.
(4) A combines with hydrogen to form a compound with the molecular formula AH_3 .

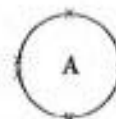

16. Select the response which states correctly the number of molecules of water present in 9 g of water. [H = 1, O = 16, Avagadro constant = $6.022 \times 10^{23} \text{ mol}^{-1}$]

- (1) $\frac{6.022 \times 10^{23}}{9 \times 18}$ (2) $\frac{18}{9} \times 6.022 \times 10^{23}$ (3) $\frac{9}{18} \times 6.022 \times 10^{23}$ (4) $9 \times 18 \times 6.022 \times 10^{23}$

17. Consider the three reactions given below.

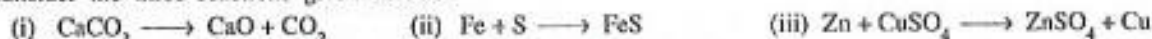

What are the types of reactions given below, to which the reactions (i), (ii) and (iii) are examples respectively?

- (1) combination, decomposition and single displacement
(2) decomposition, combination and double displacement
(3) decomposition, single displacement and combination
(4) decomposition, combination and single displacement
18. What is the measurement that is not suitable to find out the effect of concentration of hydrochloric acid on the rate of reaction between CaCO_3 and hydrochloric acid?
(1) volume of CO_2 evolved during a unit time (2) time taken to evolve a unit volume of CO_2
(3) time taken to initiate evolution of CO_2 (4) time taken for evolution of CO_2 to terminate
19. The composition of a solution of sodium chloride is 58.5 g dm^{-3} . What is the response that gives the composition of this solution expressed correctly in another way? [Na = 23, Cl = 35.5]
(1) 58.5 mol dm^{-3} (2) 5.85 mol dm^{-3} (3) 1 mol dm^{-3} (4) 0.1 mol dm^{-3}
20. Given below are some characteristics that are common to a certain group of elements. They
● are solids at room temperature. ● are good conductors of heat. ● form basic oxides
This group of elements belongs to,
(1) metals. (2) non-metals. (3) metalloids. (4) noble gases.

21. The element that is used in vulcanizing rubber as well as a fungicide is
 (1) C (2) N (3) Na (4) S
22. Which reaction given below would show a colour change during heating?
 (1) $2\text{NaHCO}_3(\text{s}) \longrightarrow \text{Na}_2\text{CO}_3(\text{s}) + \text{CO}_2(\text{g}) + \text{H}_2\text{O}(\text{g})$ (2) $\text{CuSO}_4 \cdot 5\text{H}_2\text{O}(\text{s}) \longrightarrow \text{CuSO}_4(\text{s}) + 5\text{H}_2\text{O}(\text{g})$
 (3) $\text{CaCO}_3(\text{s}) \longrightarrow \text{CaO}(\text{s}) + \text{CO}_2(\text{g})$ (4) $\text{Na}_2\text{CO}_3 \cdot 10\text{H}_2\text{O}(\text{s}) \longrightarrow \text{Na}_2\text{CO}_3(\text{s}) + 10\text{H}_2\text{O}(\text{g})$
23. Which one of the following gives the correct number of atoms of carbon, oxygen, nitrogen and hydrogen respectively, in a molecule of urea $\text{CO}(\text{NH}_2)_2$?
 (1) 1, 1, 1 and 2 (2) 2, 2, 2 and 4 (3) 1, 1, 2 and 4 (4) 1, 1, 2 and 2
24. The raw materials used in the large scale extraction of essential oils in Sri Lanka are
 (1) cinnamon and citronella. (2) cardamom and nutmeg.
 (3) lemon grass and pinus. (4) clove and rose.
25. A balloon filled with air and tied to a large mass is immersed in the water in a reservoir. Which graph illustrates correctly the variation of the distance (d) travelled by the balloon from the surface of water longitudinally downwards and the volume (V) of the balloon?

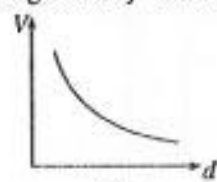

(1)

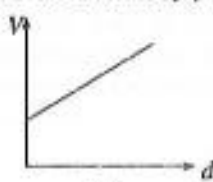

(2)

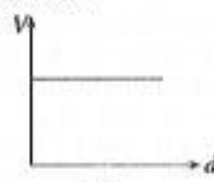

(3)

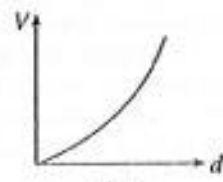

(4)

26. What principle out of those given below is used in the photocopying machine?
 (1) Electrolysis (2) Transference of heat
 (3) Electrostatic charges (4) Electrodynamics
27. For light rays to undergo total internal reflection,
 A - light rays should enter from a denser medium to a rarer medium.
 B - the angle of incidence in the denser medium should be greater than the critical angle.
 C - light rays should enter from a rarer medium to a denser medium.
 D - the angle of incidence in the rarer medium should be greater than the critical angle.
 Out of the above the correct ones are
 (1) A and B only. (2) A and C only. (3) C and D only. (4) all are correct.
28. What should be done to increase the mechanical advantage of any machine?
 (1) Increase the length of the effort arm irrespective of the load
 (2) Increase the length of the load arm more than that of the effort arm
 (3) Decrease the effort relative to the load
 (4) Nothing can be stated as the type of machine is not known
29. Multiflexing method is used, in transmitting information in communication, using wires as well as in wireless communication. What is referred to as multiflexing is
 (1) sending a large number of signals at a time through one channel.
 (2) using several channels to send a large number of signals.
 (3) sending a signal to several transmission towers through one channel.
 (4) sending various signals at different instances through one channel.
30. Fleming's left hand rule can be used
 (1) to find the direction of current induced by the movement of a conductor kept in a magnetic field.
 (2) to find the direction of movement of a conductor carrying a current when kept in a magnetic field.
 (3) to find the direction of the magnetic field around a conductor carrying a current.
 (4) to find the direction of movement of a conductor carrying a current.
31. Consider the statements given below regarding the electrical accessories used in a household electrical circuit.
 A - the electricity supply to the house can be disconnected when necessary by the service fuse.
 B - the tripe switch is placed at a point before the service fuse.
 C - electricity is distributed to various parts of the house by the fuse box.
 D - the electricity supplied to the house is controlled by the electric meter.
 Out of these the correct ones are
 (1) A, B and C only. (2) A and C only. (3) A and D only. (4) B and D only.

32. Given here is a time-displacement graph drawn using the data gathered during a laboratory experiment carried out by a group of students, regarding the movement of a trolley. Which time-velocity graph given below could fit most appropriately to the movement of the trolley?

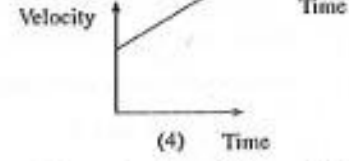
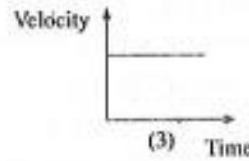
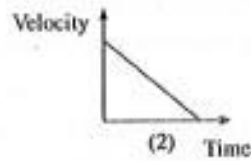
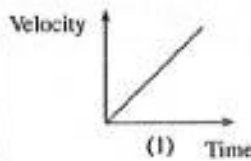
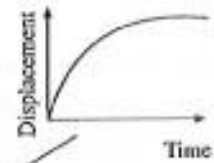

33. An object of mass m placed on a smooth horizontal table, is moved by applying a horizontal force F . If the mass of the object is doubled and is moved by applying the same horizontal force F , the new acceleration with which the object can move is
 (1) half the acceleration at the first instant. (2) twice the acceleration at the first instant.
 (3) equal to the acceleration at the first instant. (4) $\frac{1}{4}$ of the acceleration at the first instant.

34. An instance where a hydrometer is immersed in a vessel of water is shown in the diagram. The length of the part of the hydrometer that is dipped inside the water is x and the length of the part that is above the water is y . If kerosene oil is used instead of water the value of y ,
 (1) will not change. (2) will be less than x .
 (3) will decrease. (4) will increase.

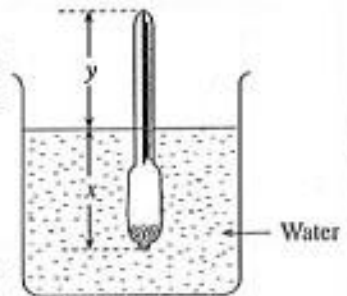

35. A diagram of a logic gate is given below. A and B are inputs while Z is the output. Select the response which gives the values that the input signals could have for the output to be '1', when considering the higher voltage signal level as '1' and lower voltage signal as '0'
 (1) $A = 1, B = 0$ (2) $A = 0, B = 1$
 (3) $A = 0, B = 0$ (4) $A = 1, B = 1$



- Answer the questions 36 and 37 using the following diagram.

This diagram illustrates a rectifier model circuit planned by a student. L_1, L_2, L_3, L_4, L_5 and L_6 are six identical LEDs.

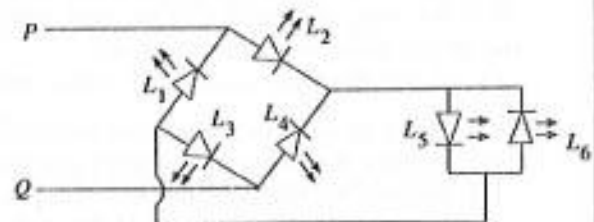

36. Which LEDs will light up when the positive terminal of a supply of 6 V direct current is connected to P and the negative terminal is connected to Q
 (1) L_2, L_5, L_3 (2) L_2, L_3, L_3 (3) L_2, L_6, L_4 (4) L_1, L_4, L_5
37. What observation could be made out of the following when an alternate current supply of 6 V, 50 Hz is connected in between P and Q ?
 (1) All LEDs will light up (2) L_2, L_3, L_5 and L_1, L_4, L_6 will light up alternately
 (3) L_1, L_2, L_3, L_4, L_5 will keep continuously lighted (4) Only L_1, L_2, L_3, L_4 will light up
38. What could be the group of chemical substances which possesses all of the characteristics given below. They
 ● remain unchanged in the environment for a long time. ● are poisonous.
 ● spread across a wide area.
 ● accumulates in the bodies of living organisms via food chains.
 (1) detergents. (2) germicides. (3) pesticides. (4) preservatives.
39. During the past few days health officials have focused their attention on using a certain species of bacteria to control the dengue mosquito menace in Sri Lanka. This method of control is an example for
 (1) chemical control. (2) physical control. (3) biological control. (4) massacre.
40. The depletion of the ozone layer could be regarded as an unfavourable result of the changes in the balance of the natural environment caused by human activities. An adverse effect directly experienced by man due to this is
 (1) global warming. (2) rising of the sea level.
 (3) falling prey to respiratory diseases. (4) falling prey to skin cancers.

13604

ශ්‍රී ලංකා විභාග දෙපාර්තමේන්තුව
 Department of Examinations, Sri Lanka
 இலங்கைப் பரீட்சைத் திணைக்களம்
 Department of Examinations, Sri Lanka

34 E II

අධ්‍යයන පොදු සහතික පත්‍ර (සාමාන්‍ය පෙළ) විභාගය, 2009 දෙසැම්බර්
கல்விப் பொதுத் தராதரப் பத்திர (சாதாரண தர)ப் பரீட்சை, 2009 டிசெம்பர்
General Certificate of Education (Ord. Level) Examination, December 2009

විද්‍යාව II விஞ்ஞானம் II Science II	පැය තුනයි முன்று மணித்தியாலங்கள் Three hours
--	---

- Instructions :**
- * Write your answers in neat hand writing.
 - * Answer four questions in Part A, in the space provided.
 - * answer three questions in Part B selecting one question each from the sections Biology, Chemistry and Physics.
 - * After answering, tie Part A and the answer script of Part B together and hand over.
- Index No. :**

Part A - Structural Essays

1. There are forces which help in the transport of water up the stem of a tree. The set-ups A and B are arranged, to demonstrate that a pulling force is exerted from the top while the set-up C demonstrates, that a pushing force is exerted from the bottom.

At the start,

- * the clay vessel and the tube in set-up A were completely filled with water, and the lower end of the tube was dipped inside the mercury in the beaker. When the water evaporates through the clay vessel, it was observed that the mercury in the beaker was rising up the longitudinal tube.
- * the tube in set-up B was completely filled with water and a plant twig was fixed to the upper end of the tube so that it is airtight while the lower end was dipped in mercury in the beaker. Here too it was observed that the mercury in the beaker was pulled up the tube.
- * the tube in set-up C below the broken line shown in the diagram was completely filled with mercury. The stem of a potted plant was cut off and the lower end of the tube filled with mercury was fixed on to the cut end of the plant, so that it was airtight, as shown in the diagram. When water was released from the stem, it was observed that the mercury column, was rising along the arm of the tube with the open end.

The diagrams here illustrate how these three set-ups are seen after a certain period of time.

- (i) What is the process taking place in a plant, that is demonstrated by the set-up A?

- (ii) When the mercury column in set-up A is rising up, will the temperature of the clay vessel decrease, increase or remain the same, relative to the temperature of the environment?

- (iii) What is the name of the structure, corresponding to the longitudinal tube in set-up A, which transports water up the stem in a plant?

- (iv) Calculate the force exerted by the plant twig to pull the mercury column up, at the instance when the mercury column in set-up B has risen 1m. (density of Hg = 13 600 kg m⁻³, area of cross section of the tube = 0.0001 m², acceleration due to gravity = 10 m s⁻²).

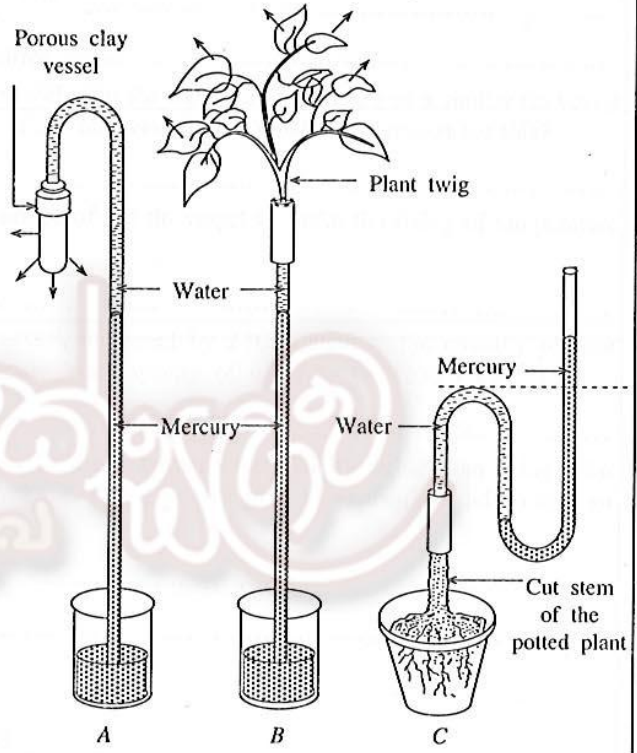

(v) The plant twig has exerted sufficient force to keep the mercury column in the tube in set-up B, raised up to 1 m. What is the height to which a column of water can be raised using the same force? (Consider that the density of Hg is 13.6 times the density of water.)

.....

(vi) A student suggests that it is better to use water for this experiment, instead of mercury, because mercury can cause environmental pollution. What is the practical problem that might be faced if water is to be used here?

.....

(vii) The table gives some data obtained by a group of students, by keeping three identical sets of B in different environments.

Environment	Height of the mercury column
Inside the laboratory	h_1
A windy place with direct sunlight	h_2
A windy place under the shade of a tree	h_3

Write down h_1 , h_2 and h_3 in the increasing order.

.....

(viii) A shoe flower plant twig and an *araliya* twig of equal size are fixed, separately, to the set-up B and kept under the same environmental conditions and the height of the mercury column is measured. Which plant twig when fixed to the set-up B, will raise the mercury column most?

.....

(ix) What is the plant process which creates the force necessary to keep the mercury column raised, as shown in set-up C?

.....

(x) Write down a statement using the following symbols, for the pressure (P) at the level shown by the broken horizontal line in the set-up C.

- atmospheric pressure = π
- weight of mercury column above the dotted line = W
- cross sectional area of the tube = A

$P = \dots + \dots$

(xi) The space above the mercury column in the open arm of the set-up C is completely filled with water and a plant twig is fixed to the open end, so that it is airtight. What change will occur in the mercury level in the tube, where the plant twig is fixed?

.....

(xii) Two samples of water, one sample collected from the water that evaporated from the plant twig and the other sample collected from the lower end of the tube in set-up C, are placed on two watch glasses separately and evaporated. What is the observation expected from this?

.....

2. A unicellular organism can perform all the biological functions necessary for its existence by itself. Multicellular organisms too can perform all the biological functions by themselves, but a single cell separated from their bodies cannot act like a unicellular organism. The reason for this is because the multicellular organism is built up according to the organizational levels of the cell, tissue, organ, system, organism in sequential order.

(i) (a) Name a protozoan organism belonging to the organizational level of the cell.

.....

(b) Name the locomotive organelle of the protozoan organism that you mentioned above.

.....

(c) What form of unit can the cell be considered as in relation to all the organisms?

.....

(ii) (a) What is the organizational level of life, where the same type of cells are grouped together to perform definite body functions?

.....

(b) Given below are diagrams of the microscopic views of two specimens taken from a plant, which illustrate the organization mentioned in (ii) (a) above. Name these two.

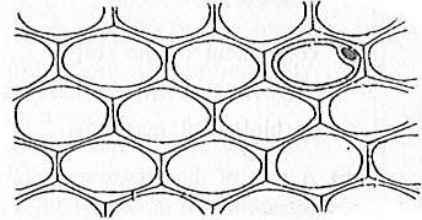
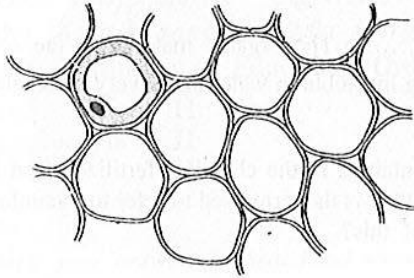

(A)

(B)

(iii) The figures 1 and 2 illustrate the diagrams of electron microscopic structures of a plant cell and an animal cell.

(a) Identify them and write on the dotted lines what they are.

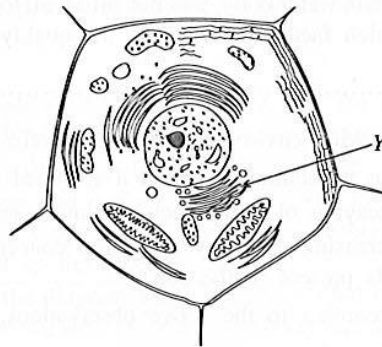
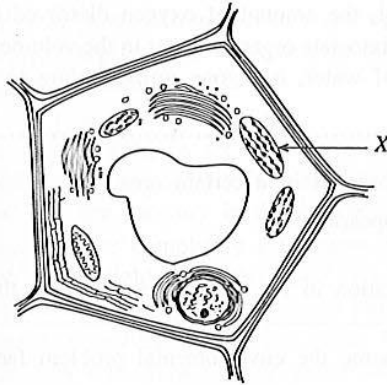

Figure 1

Figure 2

(b) State two features that the plant cell possesses which the animal cell does not have, as shown in the above diagram.

1.

2.

(c) State one function performed by each of the parts X and Y within the cell.

Function of X

Function of Y

(iv) (a) There are two ways by which the nucleus divides during cell division. State one of them.

.....

(b) What is the number of chromosomes that the daughter cell receives, from the chromosomes present in the nucleus of the mother cell, during the cell division you mentioned in (iv) (a) above?

.....

(c) The chromosomes are present in the nucleus in pairs. They are referred to as homologous chromosomes. What is a pair of homologous chromosomes?

.....

3. (i) (a) Fill in the blanks of the following paragraph using the appropriate words.
 The most important component of the earth's crust is the soil. The soil is formed by the weathering of The soil in different places contain different amounts of gravel and rough sand, fine sand, and clay particles. Based on the composition of these particles the soil is classified as clayey, sandy and The active inorganic component of the soil is The organic material in the soil which is called has properties of being insoluble in water and a very slow rate of being digested by biological reactions.

(b) A part of the nitrate and phosphate ions contained in the chemical fertilizer used in cultivated lands gets collected in water bodies around them. What is the term used to refer to the unfavourable condition occurring in the water bodies as a result of this?

.....

(c) Calcium hydrogen carbonate dissolved in water leads to temporary hardness in water. Write down the chemical equation that shows the separation of this salt from the water, when heated .

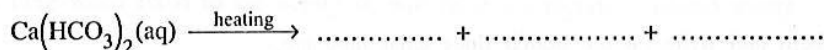

(d) It was discovered by an experiment that, the amount of oxygen dissolved in 1 dm³ of water of a certain water body, was not sufficient to dissociate organic matter in the volume, by biological functions. Which factor, determining the quality of water, has gone up according to this conclusion?

.....

(ii) The following environmental effects were observed in a certain area.

- The vegetation exhibited a scorched appearance.
- Decaying of rocks such as limestone.
- Increasing of heavy metal ion concentration in the water bodies due to the dissolution of certain salts present in the soil.

(a) According to the above observations, name the environmental problem facing this area.

.....

(b) If a sample of rain water received in this area is tested with litmus, which type of litmus will show a colour change?

.....

(c) The environmental conservationists point out that the gaseous waste produced by the factories in the area should be released to the atmosphere, after bubbling through a pulp of calcium hydroxide. What is the pollutant removed in this process?

.....

(d) The changes occurring in the rock, due to the environmental problem facing this area demonstrate a type of weathering of rock. What type of weathering of rock does this indicate?

.....

(e) Give an example of a heavy metal.

(f) A food chain functioning in the area in association with water bodies is given below.



Which animal in this food chain will largely fall prey to the effects caused due to the accumulation of heavy metals in their bodies?

.....

4. Given below is a rough diagram (not drawn to scale) of a set-up presented by a student at an exhibition, that was planned to heat water inside a house by using solar energy. A concave mirror formed by fixing thin polished aluminium plates on to a curved frame is used in it.

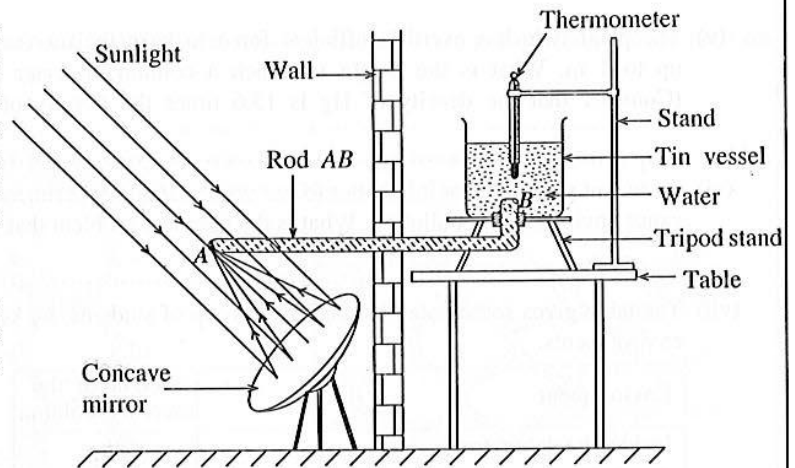

(i) The rod *AB* is made of metal. What is the property that the metal rod should possess for it to be used here?

.....

(ii) At what point of the mirror should the end *A* of the rod *AB*, be placed?

(iii) When the mirror is kept exposed to sunlight, it is observed that the mercury column in the thermometer is rising. State the method by which heat is transferred at each stage of this process as given below.

- (a) from the sun to the mirror
- (b) along the rod from *A* to *B*
- (c) through the water from the bottom of the vessel up to the surface of water
- (d) from the water to the mercury in the thermometer

(iv) The temperature of the water not increasing during a short time, was a problem for the student. Given below are some experiments carried out by him in this regard. Write down on the dotted line in front, whether the rate at which the reading of the thermometer increases, is more or less or the same, at each of these instances:

- (a) shortening the rod *AB*
- (b) covering the whole of rod *AB* except the end *A*, by wrapping with dry cloth
- (c) keeping the mirror closer to the end *A* of the rod *AB*
- (d) by blackening the inner surface of the mirror

(v) The water will get heated quicker, when the tin vessel with the rod *AB* is removed and a similar tin vessel with water is kept at the place where the end *A* of the rod was earlier. What is the reason for this?

.....

(vi) State a change that can be made on the outer surface of the tin vessel to make the rising of temperature stated in (v) above more efficient.

.....

(vii) The temperature of 100 g of water in the tin vessel, increased by 2 °C. Calculate the quantity of heat obtained, to heat the water considering the specific heat capacity of water to be 4200 J kg⁻¹ °C⁻¹.

.....

(viii) A viewer at the exhibition stated that it is easier to use a burner or electricity rather than using solar heat. As a student studying science, state two reasons that you will give to explain the advantages of using a method such as this.

- (a)
- (b)

Part B - Eassy Type Questions

Answer three questions, selecting one question from each of the sections Biology, Chemistry and Physics.
Biology

5. Animals adjust their bodies to respond to changes occurring in the external and internal environments by co-ordination and homeostasis. Reduction of the glucose level in the blood when it rises, by the insulin secreted by the cells in the pancreas, and pulling away of the hand when it touches something hot are examples for this.
- (a) State the action which is an example for homeostasis, mentioned in the paragraph above.
(b) There are two types of co-ordination namely electric and chemical. Write **two** differences between electric and chemical co-ordination.
(c) Write down in the form of a diagram, using words and arrows, the path taken by the impulse in response to the stimulus generated by the hand touching something hot.
 - Sumith met a doctor because he was very short for his age. According to medical opinion the reason for not growing tall was due to a damage caused to some part of the brain in the nervous system, by an accident, when he was small.
 - According to this opinion, what is the part of the brain to which this damage was caused?
 - Explain why this damage was a cause for his not growing tall.
 - (a) In plants too there are growth substances that affect growth and physiological activities. Name one place where these substances are produced.
(b) Hormones produced artificially are used for various needs in agriculture. State **two** such instances where artificial hormones are used.
(c) Name **one** hormone that is produced artificially.
 - Sunil is a young man but because his beard has not grown, he looks younger than his age. One day when he was going on a journey a dog jumped at him barking. As if driven by some novel form of energy he ran very fast, as he has never run before.
Explain the situations presented by the statements printed in dark letters relating them to hormone activities.
 - Sexual reproduction is important for the continuous existence of some plants. For this process which takes place through fertilization of gametes, the plants have adapted to self pollination and cross pollination. Explain the actions denoted by fertilization and cross pollination mentioned above.

6. A rough plan of the digestive tract of vertebrates is given in the diagram below.

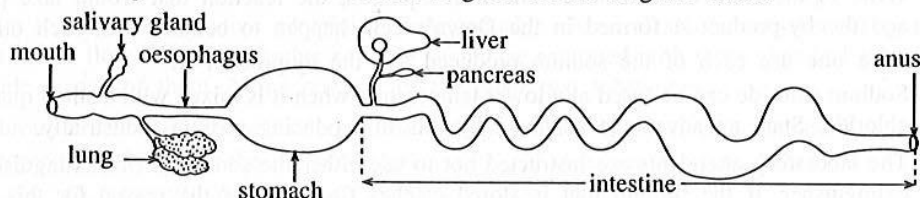

Various parts of this tubular digestive tract, which commences at the mouth and ends with the anus, are adapted to perform different functions.

- (a) State two physical actions, related to digestion of food, taking place inside the buccal cavity of some animals.
(b) Name two additional (extra) glands that are shown in the above diagram which assist in the digestion of food.
(c) Explain the manner in which food is moved in the oesophagus part of the digestive tract, with the help of the muscles situated there.
- (a) "Animals that do not have the enzyme amylase in the saliva, do not feel the taste of certain food." Explain the meaning of this.
(b) When a substance enters the stomach, the glands there get stimulated and secrete digestive juice. Name two substances contained in digestive juice, and explain the function performed by each of them.
(c) When someone stays for a long time without consuming food, the saliva and mucous flowing into the stomach also stimulates secretion of digestive juice. Describe the unfavourable effect caused on the stomach by this.
- (a) It is important that the food we consume should contain an abundance of fibre. Give the reason for this.
(b) Explain how the constituents of the fats digested in the intestine gets into the blood circulation.
(c) Transportation of substances in the plants also takes place through tissues and systems. State separately, through which tissues, the transportation of glucose, water and mineral salts take place in plants.

- (iv) (a) In both animals and plants absorption of nutrients necessary for their biological functions, takes place through surfaces specially adapted for that purpose. Name an absorption surface each, for animals and plants, adapted to absorb nutrients and state the special adaptation in them.
- (b) Absorption of nutrients along with other constituents into living bodies takes place actively as well as passively. Give one example each for an instance of active absorption and passive absorption.

Chemistry

7. (i) A rough diagram of the Down's cell used to extract the metal sodium industrially is illustrated below.

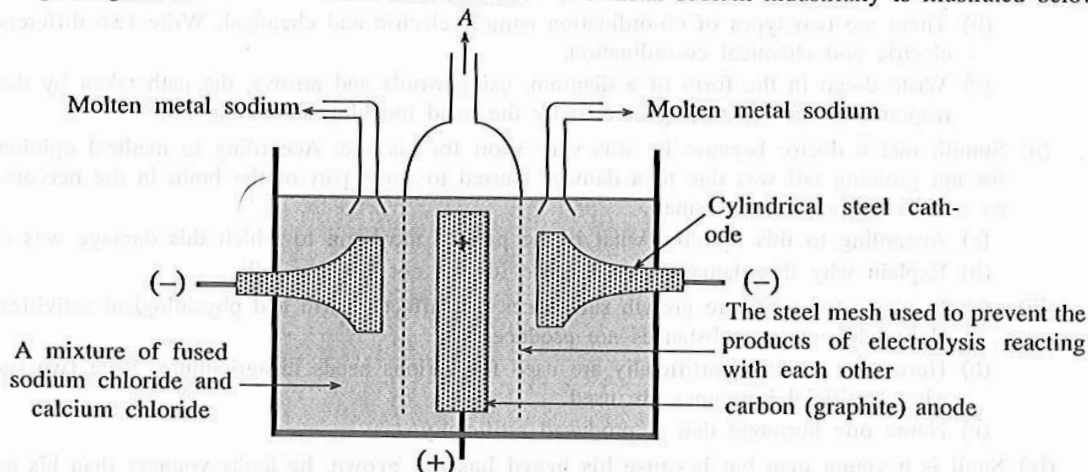

The main electrode reactions taking place in the Down's cell in relation to the extraction of sodium are given below.

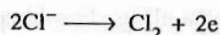
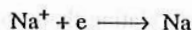

- (a) State the reactions taking place at the cathode and anode, respectively, during electrolysis in the Down's cell.
- (b) Name the by-product formed during extraction of sodium, shown in the diagram by the letter A.
- (c) Write in the form of a balanced chemical equation, the reaction that would take place, if sodium and the by-product A formed in the Down's cell, happen to contact with each other.
- (d) State **one** use each of the sodium produced and the by-product A.
- (e) Sodium chloride can be fused at a lower temperature when it is mixed with a small quantity of calcium chloride. State an advantage achieved by this in producing sodium industrially.
- (f) The laboratory attendants are instructed not to use either the soda-acid fire extinguisher or the water extinguisher, if the sodium that is stored catches fire. Explain the reason for this.
- (g) What is the fire extinguisher that is most suitable to extinguish a fire originated due to sodium catching fire?
- (ii) The iron ore commonly used in the extraction of iron is haematite containing iron(III) oxide (Fe_2O_3). The iron ore is reduced inside the Blast Furnace at a high temperature. One reaction relevant to the extraction of iron is given below.



- (a) State **two** other materials, that are mixed with iron ore and added to the Blast Furnace to extract iron.
- (b) Calculate the mass of iron that can be obtained from 160 g of haematite, assuming that haematite contains 100% Fe_2O_3 . (O = 16, Fe = 56)
- (c) Sodium and iron are extracted by subjecting, compounds containing them to chemical changes. But the metal gold is found among soil particles in a manner so that it can be separated by a physical process. Explain scientifically this observation.
- (d) Three iron nails, one with its surface cleaned well, the second with its surface completely coated with metal tin and the third with its coating of metal tin half removed, were left exposed to the atmosphere for a few days. The observations made are given below:
 Observation A - The iron nail completely coated with metal tin was not subjected to rusting.
 Observation B - The iron nail where the coating of tin metal was half removed had undergone more rusting relative to the iron nail with the cleaned surface.
 Explain scientifically the two observations A and B separately.

8. Given below is a flow chart illustrating the production of salt by the evaporation of sea water in salterns.

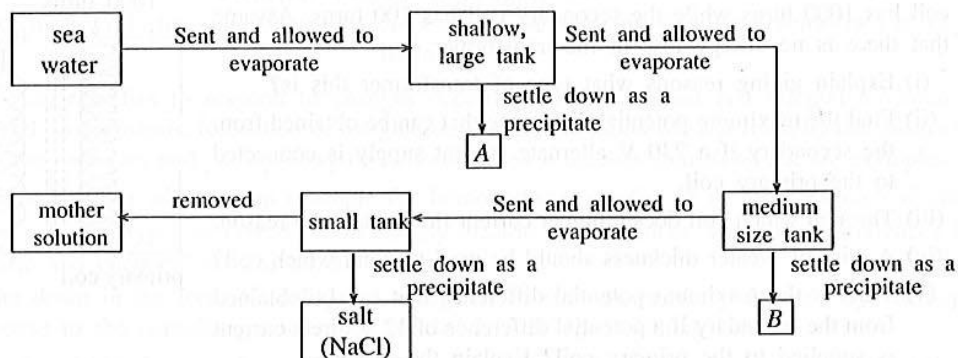

Answer the questions given below using the above flow chart as appropriate.

- (i) (a) State the main source of energy which supplies the necessary energy for the production of salt.
- (b) Explain how the collection of sea water in large shallow tanks helps in increasing the efficiency of evaporation.
- (c) "A characteristic that should be present in an area for it to be selected to build a saltern, is the presence of dry, strong winds." Do you agree with the statement? Give reasons for your answer.
- (ii) (a) A solid substance dissolved in a solution can be separated from the solution by precipitation, using some strategy to increase the concentration of that substance in the solution. What is the name given to this process?
- (b) Name the substances indicated as A and B in the flow chart, which get precipitated when sea water is being concentrated through evaporation.
- (c) Which substance out of A and B, has the highest solubility? Give reasons for your answer.
- (d) State one use of the by product A in the flow chart.
- (iii) The salt that gets precipitated in the small tanks, is sometimes bitter in taste and becomes wet when exposed to the air, which creates a problematic situation.
 - (a) Name a constituent which causes the above mentioned problematic situation.
 - (b) State a course of action that could be followed during salt production to overcome this problem.
- (iv) Mother solution is a mixture containing some valuable chemical substances. According to the process given in the flow chart, the mother solution should be saturated with three chemical substances. Sodium chloride is one of them. Name one out of the other two substances.
- (v) The bromide ion (Br^-) concentration of the mother solution is about 0.04 mol dm^{-3} . Bromine (Br_2) can be prepared by bubbling the mother solution with chlorine gas as given below.

$$\text{Cl}_2(\text{g}) + 2\text{Br}^-(\text{aq}) \longrightarrow 2\text{Cl}^-(\text{aq}) + \text{Br}_2(\text{aq})$$
 - (a) What is the number of moles of bromine (Br_2) that can be produced from 1 dm^3 of mother solution?
 - (b) What is the mass of bromine (Br_2) that can be prepared from 1 dm^3 of mother solution? ($\text{Br} = 80$)

Physics

9. (A) In the circuit shown in the diagram LM is a resistance wire of length l . A current can be sent through it. The other wires are conductor wires of which the resistance can be neglected. A student wants to measure the current flowing through LM and the potential difference at the two ends of LM. An ammeter, a voltmeter and additional conductor wires are provided.

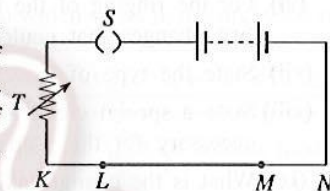

- (i) Draw this circuit again including the ammeter $\text{---} \text{ⓐ} \text{---}$ and the voltmeter $\text{---} \text{Ⓥ} \text{---}$ in the circuit. The (+) and (-) terminals of the apparatus should be indicated correctly.
- (ii) State what T and S are and write down one use each of T and S.
- (iii) Write down an expression for R where the resistance of the wire LM is R, length is l , area of cross section is a and resistivity is ρ .
- (iv) State Ohm's Law and give one condition for Ohm's Law to be true.
- (v) If the potential difference at the two ends of the wire LM is 2 V and the current flowing is 0.5 A, find the resistance of the wire LM and state its units.

(B) A rough sketch of a transformer is given in the diagram. The primary coil has 1000 turns while the secondary coil has 100 turns. Assume that there is no energy loss in the transformer.

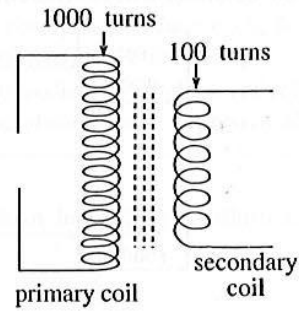

- (i) Explain giving reasons what type of transformer this is?
- (ii) Find the maximum potential difference that can be obtained from the secondary if a 230 V alternate current supply is connected to the primary coil.
- (iii) Through which coil does a higher current flow? State the reason.
- (iv) A wire of greater thickness should be used to wind which coil?
- (v) What is the maximum potential difference that can be obtained from the secondary if a potential difference of 12 V direct current is supplied to the primary coil? Explain the reason.

10. The diagram illustrates a model of the set-up, which is referred to as 'diya holmana' (water ghost), which is attached to a small water spout, used by farmers to chase away the animals coming to paddy fields. The bamboo stick *AB* is set in a manner so that it can rotate around the horizontal rod *PQ*. When water is getting filled into the bamboo at the end *B*, at a certain stage the end *B* lowers down. Then the water filled inside the bamboo is released, and the end *B* goes up again and gets filled with water as before. This chain of action is repeated continuously. There is a weight *W*, fixed to a ring at the end *A* of the bamboo. One end of a light string is fixed to this ring and the other end connected to a bell. When the string is jerked the bell rings. The motion can be initiated by arranging a suitable weight *W* and the length of the string. The bell will ring at regular intervals.

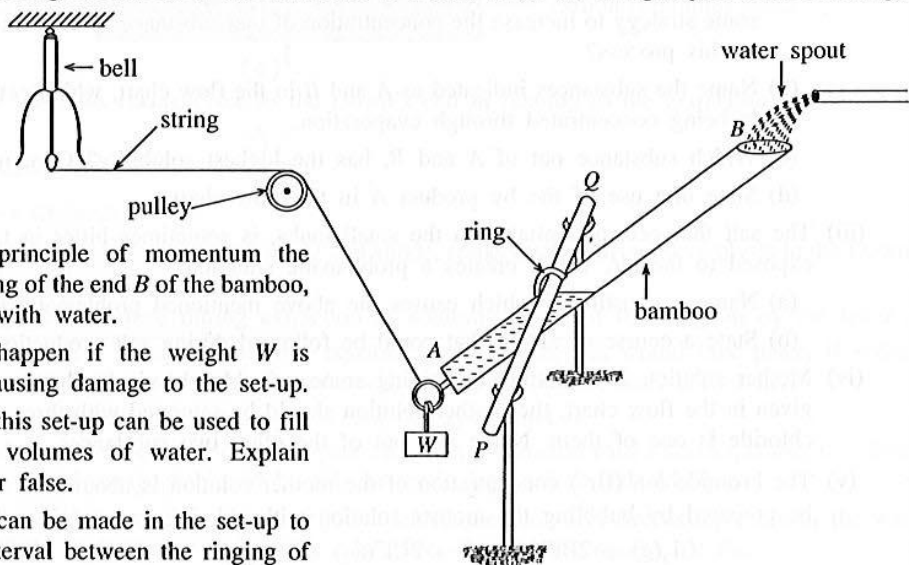

- (i) Explain using the principle of momentum the reason for the lowering of the end *B* of the bamboo, when it gets filled with water.
- (ii) Explain what can happen if the weight *W* is increased without causing damage to the set-up.
- (iii) A student says that this set-up can be used to fill vessels with equal volumes of water. Explain whether it is true or false.
- (iv) State a change that can be made in the set-up to increase the time interval between the ringing of the bell.
- (v) Filling of water into the bamboo $\xrightarrow{(a)}$ motion of the bamboo $\xrightarrow{(b)}$ ringing of the bell.
State the energy conversions taking place at stage (a) and stage (b) separately.
- (vi) For the ringing of the bell to be heard at a distance, it should be moved with a greater force. Suggest two changes that could be made in this set-up to achieve this purpose.
- (vii) State the type of waves through which sound travels from the bell to the ear.
- (viii) State a special characteristic present in the type of wave mentioned in (vii) above and state a condition necessary for the propagation of the wave.
- (ix) What is the change taking place in the sound wave emitted when the bell is rung using a greater force?
- (x) State two properties that remain unchanged in the sound wave emitted when the bell is rung exerting a greater force.
- (xi) Calculate the wave length of a sound wave of frequency 1000 Hz (Consider the velocity of sound in air as 340 m s^{-1})
- (xii) A student expects to use this set-up in a farm to chase away the birds. State the basic requirement necessary for the set-up to function continuously.
- (xiii) There is a problem of the string loosening and jumping off the pulley, when the set-up is functioning. Suggest a method that can be implemented to overcome this problem.