

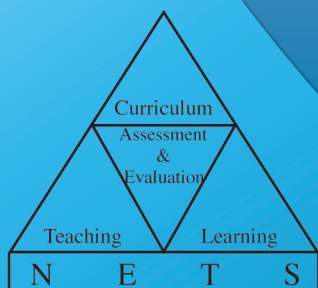

G.C.E.(A.L.) Examination - 2016

Evaluation Report

02 - Chemistry



**Research & Development Branch
National Evaluation & Testing Service
Department of Examinations**

G.C.E.(A.L.) Examination - 2016

Evaluation Report

02 - Chemistry

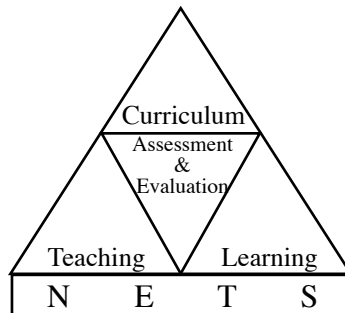

**Research and Development Branch
National Evaluation and Testing Service
Department of Examinations**

All Rights Reserved

Chemistry

Evaluation Report - G.C.E.(A.L.) Examination - 2016

Financial Aid

Transforming the School Education System as the Foundation
of a Knowledge Hub Project (TSEP-WB)

INTRODUCTION

The General Certificate of Education (Advanced Level) Examination is the final certification examination of the Senior Secondary Education in Sri Lanka. Though certification of the students' achievement level at the end of Senior Secondary Education is the major aim of this examination, it bears a momentous position as an achievement test as well as a selection test because the eligible candidates for national universities and other higher education and vocational training institutes and also for the National Colleges of Education are selected on the results of this examination. This has also been accepted as an examination that certifies entry qualifications for the tertiary level employments. In the year 2016, 211865 school candidates and 46328 private candidates sat this examination.

Much pains are being taken by students to have a high achievement level at this examination and teachers and parents to fulfil their expectations. This evaluation report has been prepared by the Department of Examinations to assist the realization of their goals. It is certain that the information provided by this evaluation report is equally important for candidates, teachers, principals, in-service advisers, subject directors, parents and researchers in education. So it is appropriate to tender this report for wider reference.

This evaluation report comprises of three parts. I, II and III. Part I of this report consists of information related to aims and achievement of the subject Chemistry in G.C.E. (A.L) Examination. Presented under it are the statistical information on subject achievement, that is number of candidates sat for the subject, how they have obtained grades, how school candidates have obtained grades by district and distribution of marks according to class intervals and a comprehensive analysis of the subject achievement that reveals how candidates have selected questions in Papers I and II in Chemistry and how they have scored marks for the questions in them and the sub parts of each question. Part II of this report presents the questions in Paper I and Paper II of Chemistry in the G.C.E. (A.L) Examination 2016 and information about the candidates' responses to them. It encompasses expected answers for the questions of papers I and II, the mark scheme, observations on answers, conclusions and constructive suggestions.

This evaluation report prepared by the Research and Development Branch of the Department of Examinations is based on the information, observations, ideas and suggestions provided by chief examiners, additional chief examiners and assistant examiners involved in evaluating answer scripts and the information drawn through the analysis of candidates' responses using the Classical Test Theory and the Item Response Theory.

Part III of this report embodies the facts that should be taken into consideration by the candidates when answering each question and opinions and suggestions with regard to the learning teaching process. I think that this report is of immense value in the organization of the learning teaching process to achieve respective competencies and competency levels. You are kindly requested to direct your productive ideas and suggestions to us to improve the quality of our future evaluation reports.

I wish to extend my sincere thanks to the chief examiners, additional chief examiners and assistant examiners who provided information to prepare this report, the committee members who fervently and actively contributed to the task, the officers and the staff of the Department of Examinations who shouldered the responsibility, State Printing Co-operation who printed this material and the TSEP-WB that provided financial assistance for it.

B. Sanath Pujitha
Commissioner General of Examinations

01st December 2017
Research & Development Branch
National Evaluation & Testing Service
Department of Examinations.
Pelawatta, Battaramulla

Guidance	:	B. Sanath Pujitha Commissioner General of Examinations
Direction and Organization	:	Gayathri Abeygunasekera Commissioner of Examinations (Research/Development and Evaluation)
Co-ordination	:	Hasantha Kuruppu Assistant Commissioner of Examinations (Research and Development)
Editing	:	Prof. H.M.D. Namal Priyantha Department of Chemistry University of Peradeniya Dr. M.A.B. Prashantha Department of Chemistry University of Sri Jayawardhanapura
Panel of Writers	:	R.M.K.M. Rathnathilaka Sri Lanka Teachers' Service Kingswood Vidyalaya Kandy M.A.K.N. Perera Sri Lanka Principals' Service WP/GM/Mabima Vidyakara Maha Vidyalaya Makewita V.C.K.J. Munasinghe Sri Lanka Principals' Service Richmond College Galle M.J. Hapuarachchi Sri Lanka Teachers' Service (Retired) Richmond College Galle H.M.D. Darshani Deepika Menike Sri Lanka Teachers' Service Viharamaha Devi Balika Vidyalaya Kiribathgoda
Translation	:	Anuja Perera Sri Lanka Teachers' Service Princess of Wales Collage Moratuwa
Computer Type Setting	:	Anusha Maduwanthi Dissanayake ICT Assistant
Cover Page Designing	:	Y.S. Anuradhi Development Officer

Contents

	Page
Part I	
1 Subject objectives and information on subject achievement	
1.1 Subject objectives	1
1.2 Statistical information on subject achievement	
1.2.1 Number of candidates sat for the subject	2
1.2.2 Grades obtained by the candidates	2
1.2.3 Grades obtained by school candidates who sat the examination for the first time - Districtwise	3
1.2.4 Marks obtained according to calss intervals	4
1.3 Analysis of subject achievement	
1.3.1 Achievement in Paper I	5
1.3.2 Selection of questions in Paper II	6
1.3.3 Scoring for the questions in Paper II	6
1.3.4 Achievement in Paper II	7
Part II	
2 Information on questions and answers	
2.1 Question Paper I and Information on answers to Paper I	
2.1.1 Structure of the Paper I	10
2.1.2 Paper I	11
2.1.3 Expected answers and the marking scheme for Paper I	18
2.1.4 Observations on the responses to Paper I (by subject area)	19
2.1.5 Responses to the options in Paper I (as a percentage)	21
2.1.6 Overall observations, conclusions and suggestions regarding the answers to Paper I	22
2.2 Paper II and information on answers	
2.2.1 Structure of the Paper II	24
2.2.2 Selection and facility of questions in Paper II	25
2.2.3 Expected answers, mark scheme, observations, conclusions and suggestions related to Paper II	26
2.2.4 Overall observations, conclusions and suggestions regarding the answers to Paper II	67
Part III	
3 Facts to be considered when answering questions and suggestions	
3.1 Facts to be considered when answering	68
3.2 Comments and suggestions about the teaching learning process	71

Part I

1. Subject objectives and information on subject achievements

1.1 Subject objectives

After following this course the student will :

- * understand the basic concepts in chemistry required to comprehend the physical foundation of scientific explanations of natural phenomena.
- * become knowledgeable about the total framework of chemistry including its main concepts, unifying themes and patterns enabling to understand the structure and changes in matter and lay the foundation for students who pursue the study of further chemistry in the future.
- * incline to understand and appreciate the nature of the scientific process through direct experiences and inquiring into the historical development of chemistry.
- * understand the limits of science and how it is applied in relation to technical, economic, social and personal development.
- * understand the physico - chemical foundation of problems relating to the scientific usage and conservation of resources acquiring a general knowledge of them with special attention to the conditions prevailing in Sri Lanka.
- * acquire knowledge and skills required for the application of basic concepts in chemistry for technical, social and economic development with special attention to Sri Lanka.
- * develop interest for applying the knowledge and skills gained through the course for socio - economic development and conservation and utilization of natural resources.

1.2 Statistical information on subject achievement

1.2.1 Number of candidates sat for the subject

Medium	School	Private	Total
Sinhala	53178	13306	66484
Tamil	8940	1696	10636
English	2926	583	3509
Total	65044	15585	80629

Table 1

1.2.2 Grades obtained by the candidates

Grade	School Candidates		Private Candidates		Total	Percentage
	Number	Percentage	Number	Percentage		
A	3473	5.34	993	6.37	4466	5.54
B	5204	8.00	1646	10.56	6850	8.50
C	13449	20.68	3463	22.22	16912	20.98
S	21492	33.04	4843	31.07	26335	32.66
F	21426	32.94	4640	29.77	26066	32.33
Total	65044	100.00	15585	100.00	80629	100.00

Table 2

1.2.3 Grades obtained by school candidates who sat the examination for the first time - Districtwise

District	No. Sat	Distinction (A)		Very Good Pass (B)		Credit Pass (C)		Ordinary Pass (S)		Pass (A+B+C+S)		Failed (F)	
		Number	%	Number	%	Number	%	Number	%	Number	%	Number	%
1. Colombo	5997	451	7.52	563	9.39	1291	21.53	1978	32.98	4283	71.42	1714	28.58
2. Gampaha	3510	131	3.73	228	6.50	671	19.12	1130	32.19	2160	61.54	1350	38.46
3. Kalutara	2125	45	2.12	106	4.99	349	16.42	740	34.82	1240	58.35	885	41.65
4. Kandy	2987	121	4.05	167	5.59	504	16.87	985	32.98	1777	59.49	1210	40.51
5. Matale	678	11	1.62	24	3.54	105	15.49	223	32.89	363	53.54	315	46.46
6. Nuwara Eliya	907	10	1.10	37	4.08	120	13.23	257	28.34	424	46.75	483	53.25
7. Galle	2568	109	4.24	168	6.54	477	18.57	841	32.75	1595	62.11	973	37.89
8. Matara	2019	102	5.05	124	6.14	331	16.39	672	33.28	1229	60.87	790	39.13
9. Hambantota	1394	40	2.87	61	4.38	212	15.21	507	36.37	820	58.82	574	41.18
10. Jaffna	1234	132	10.70	127	10.29	281	22.77	368	29.82	908	73.58	326	26.42
11. Kilinochchi	170	8	4.71	8	4.71	26	15.29	58	34.12	100	58.82	70	41.18
12. Mannar	164	1	0.61	13	7.93	24	14.63	48	29.27	86	52.44	78	47.56
13. Vavuniya	298	16	5.37	11	3.69	42	14.09	100	33.56	169	56.71	129	43.29
14. Mullativu	167	5	2.99	7	4.19	22	13.17	60	35.93	94	56.29	73	43.71
15. Batticaloa	715	51	7.13	70	9.79	140	19.58	245	34.27	506	70.77	209	29.23
16. Ampara	1204	39	3.24	53	4.40	185	15.37	395	32.81	672	55.81	532	44.19
17. Trincomalee	490	32	6.53	47	9.59	84	17.14	147	30.00	310	63.27	180	36.73
18. Kurunegala	3066	80	2.61	124	4.04	469	15.30	985	32.13	1658	54.08	1408	45.92
19. Puttalam	1111	29	2.61	49	4.41	175	15.75	391	35.19	644	57.97	467	42.03
20. Anuradhapura	1359	24	1.77	47	3.46	161	11.85	370	27.23	602	44.30	757	55.70
21. Polonnaruwa	514	2	0.39	8	1.56	44	8.56	142	27.63	196	38.13	318	61.87
22. Badulla	1523	61	4.01	87	5.71	255	16.74	509	33.42	912	59.88	611	40.12
23. Monaragala	658	8	1.22	20	3.04	69	10.49	242	36.78	339	51.52	319	48.48
24. Ratnapura	1794	58	3.23	107	5.96	350	19.51	616	34.34	1131	63.04	663	36.96
25. Kegalle	1668	23	1.38	59	3.54	258	15.47	604	36.21	944	56.59	724	43.41
All Island	38320	1589	4.15	2315	6.04	6645	17.34	12613	32.91	23162	60.44	15158	39.56

Table 3

1.2.4 Marks obtained according to class intervals

Class Interval	Frequency	Frequency Percentage	Cumulative Frequency	Cumulative Frequency Percentage
91 - 100	62	0.08	80629	100.00
81 - 90	1299	1.61	80567	99.92
71 - 80	4821	5.98	79268	98.31
61 - 70	7792	9.66	74447	92.33
51 - 60	10352	12.84	66655	82.67
41 - 50	14141	17.54	56303	69.83
31 - 40	16091	19.96	42162	52.29
21 - 30	16286	20.20	26071	32.33
11 - 20	9467	11.74	9785	12.14
01 - 10	317	0.39	318	0.39
00 - 00	1	0.00	1	0.00

Table 4

According to the above table the number of candidates scoring from 21 - 30 is 16286. As a percentage it is 20.20. The number scoring 30 or below marks is 26071 and as a percentage it is 32.33.

1.3 Analysis of Subject Achievement

1.3.1 Achievement in Paper I

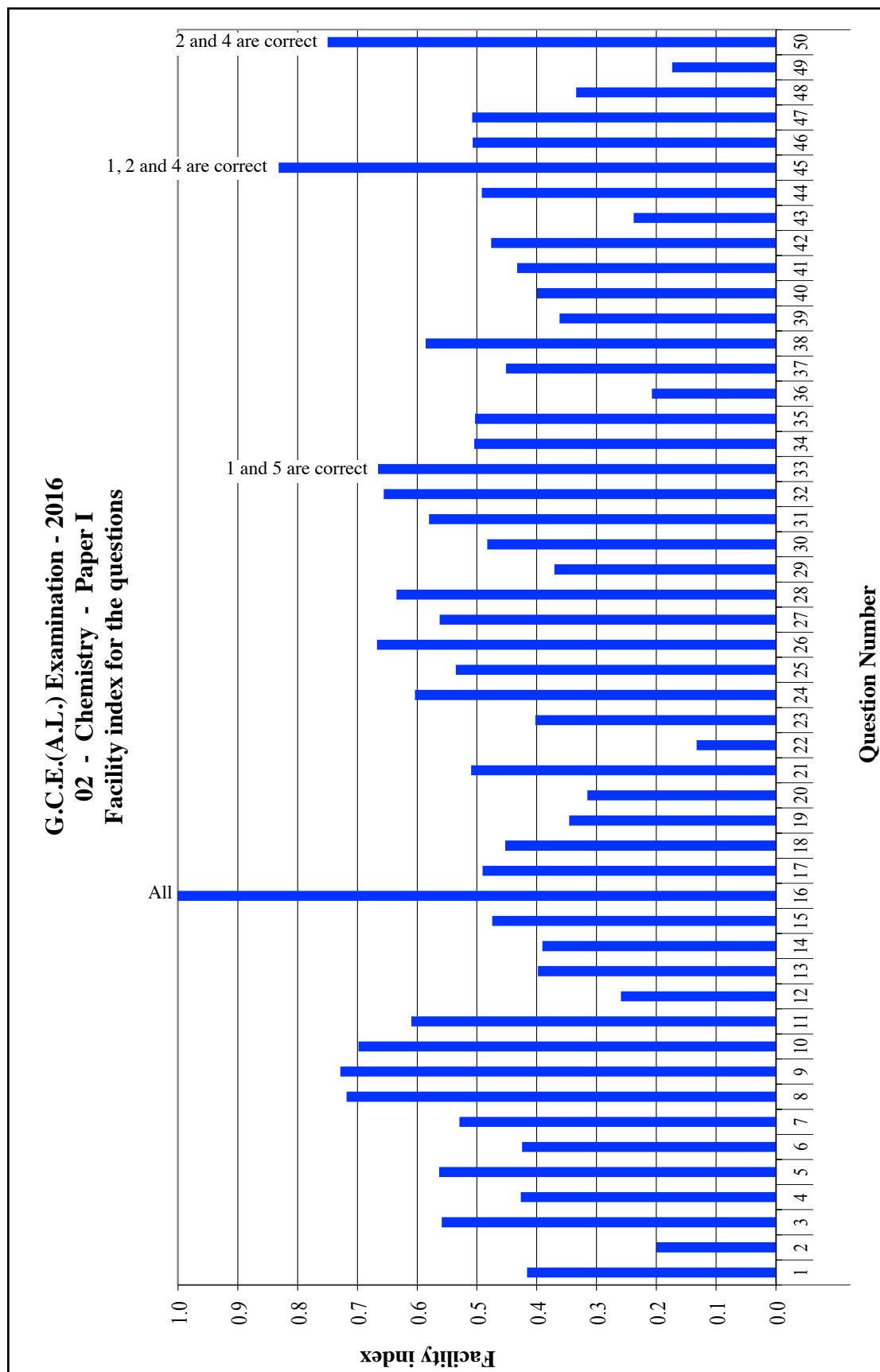

Graph 1 (Prepared using the information collected from form RD/16/05/AL) According to the above graph highest number of candidates has correctly responded to question 9. Its percentage is 73%. Least number of candidates has correctly responded to question 22. Its percentage is 13%.

1.3.2 Selection of questions in Paper II

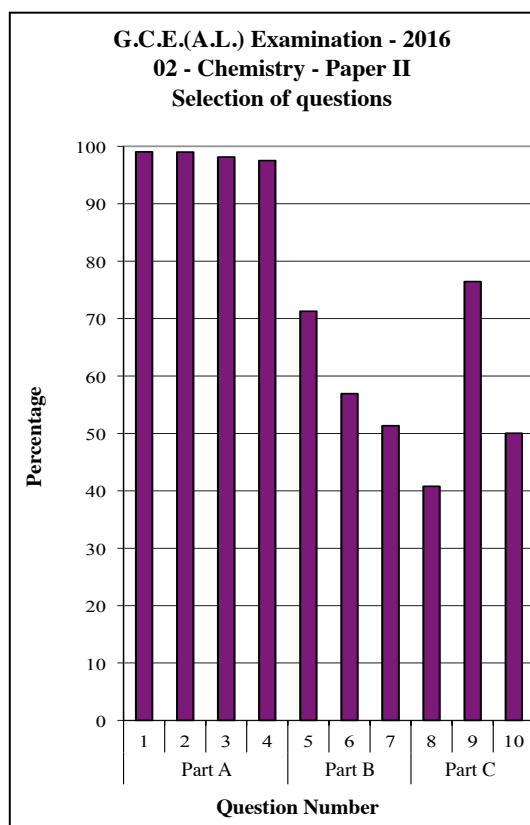

Though questions 1 - 4 were compulsory, a small number has not answered even the compulsory questions. Nearly 99% have answered question 1.

Of the questions from 5 - 10 in part B and C, the question chosen by most is 9 and as a percentage it is 76%. Question 8 has been selected by a least number of candidates. The percentage selecting it is about 40%.

Graph 2 (Prepared using the information collected from the form RD/16/02/AL)

1.3.3 Scoring for the questions in Paper II

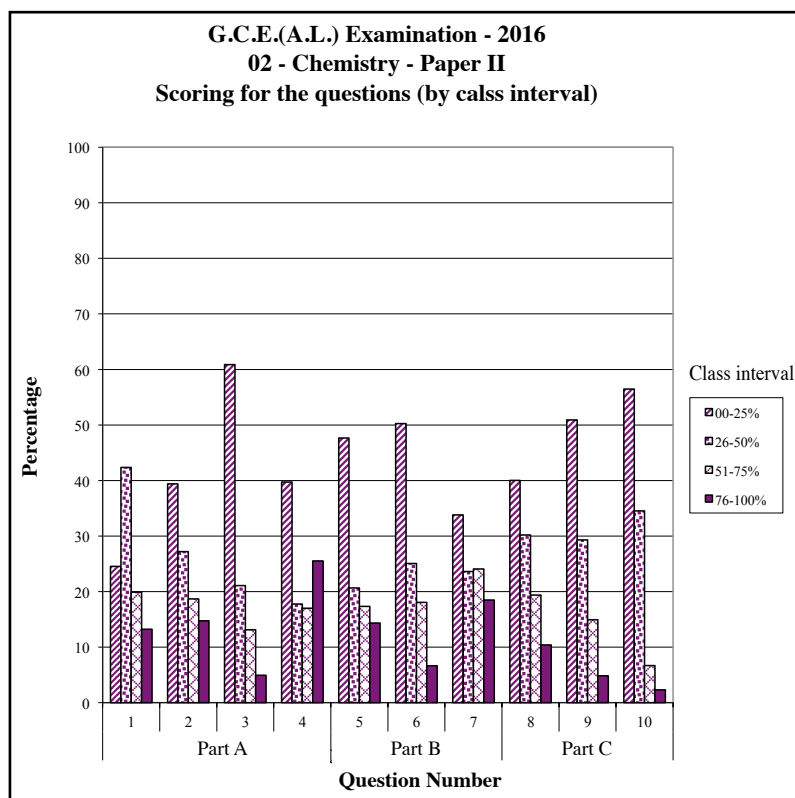

As an example marks allocated for question 1 is 100. The percentage scoring within the range 76% - 100% is 13%. The percentage getting between 00% and 25% of the 100 marks set apart was about 24%.

Graph 3 (Prepared using the information collected from the form RD/16/02/AL)

1.3.4 Achievement in Paper II

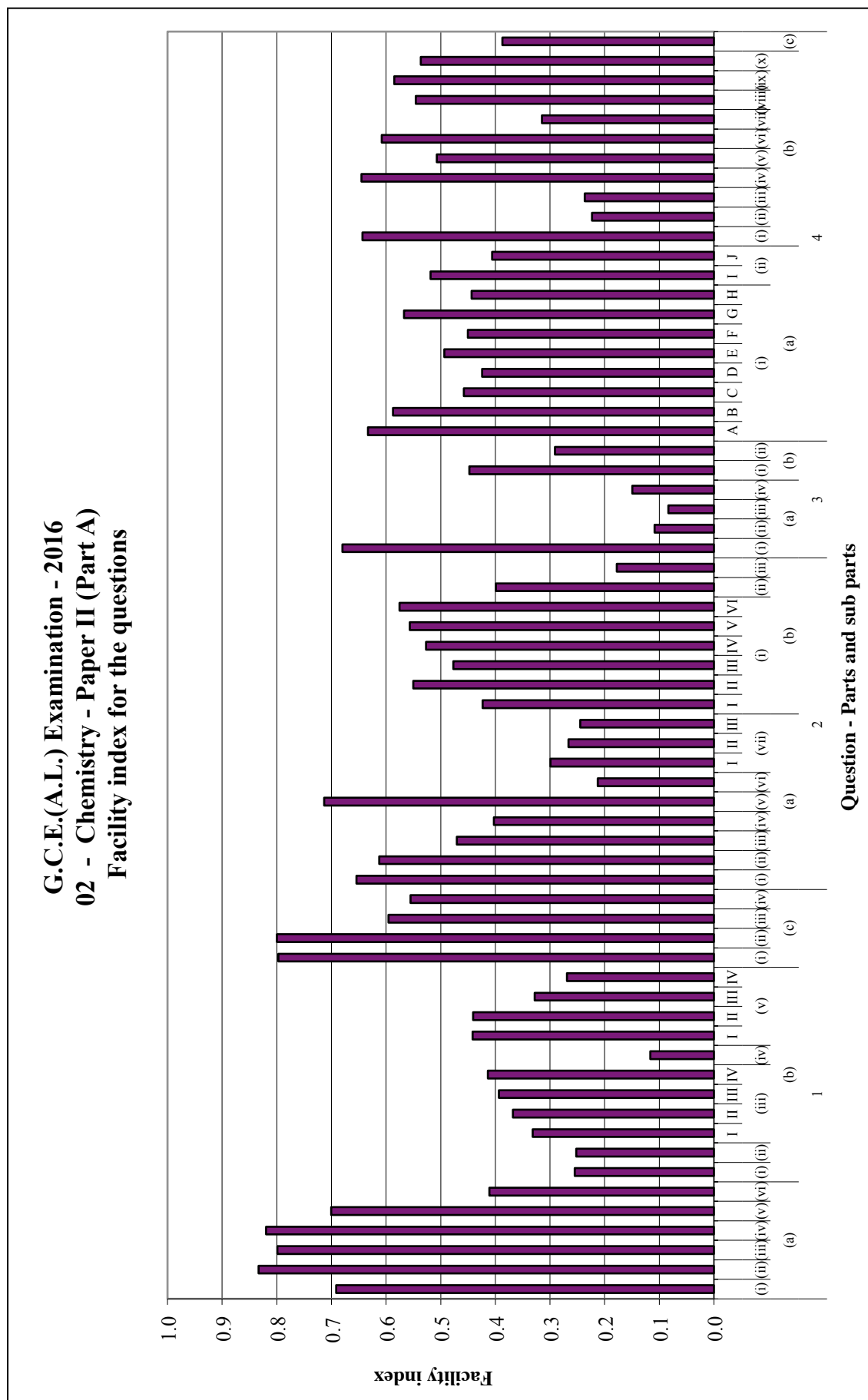

Graph 4.1 (Prepared using the information collected from the form RD/16/04/AL)

G.C.E.(A.L.) Examination - 2016
02 - Chemistry - Paper II (Part B)
Facility index for the questions



Question - Parts and sub parts

Graph 4.2

G.C.E.(A.L.) Examination - 2016
02 - Chemistry - Paper II (Part C)
Facility index for the questions

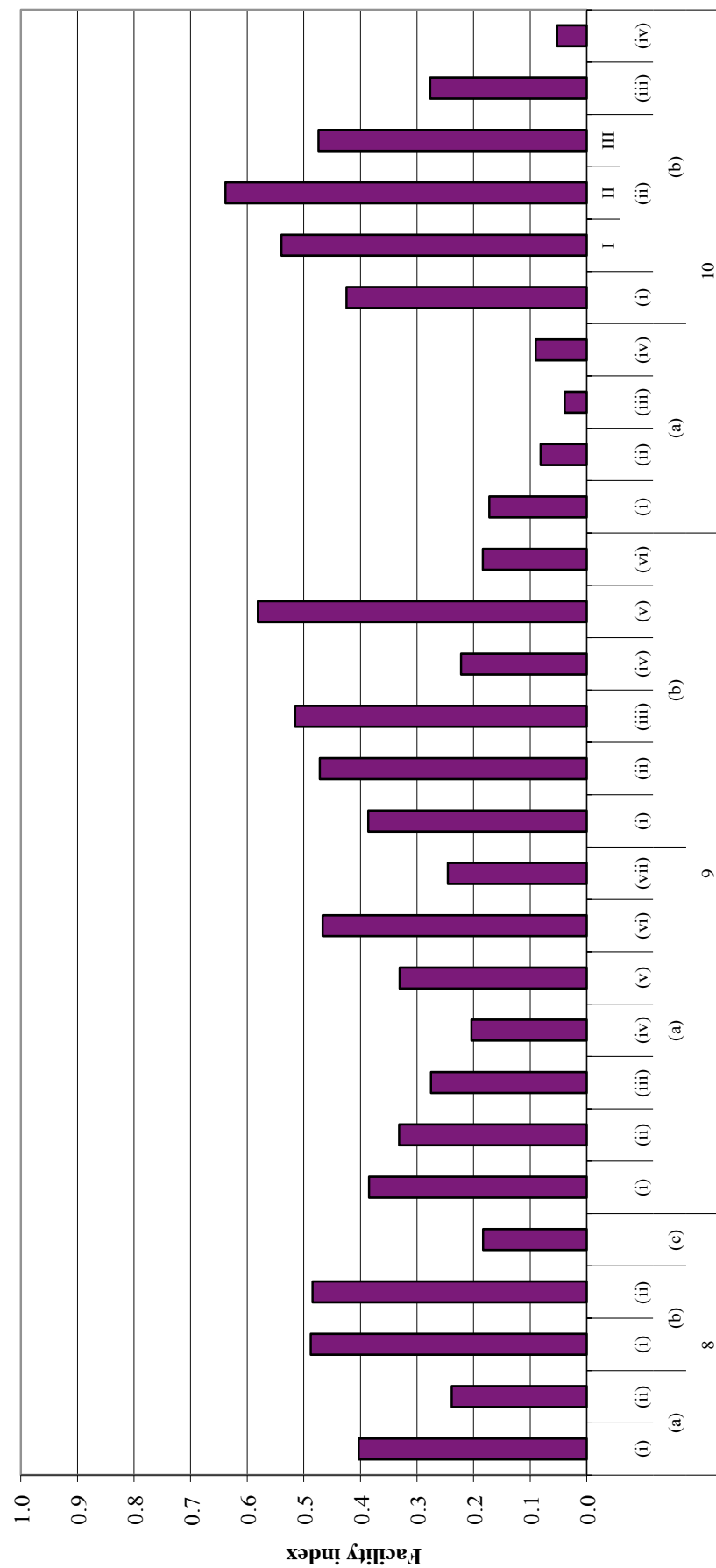

Question - Parts and sub parts

Graph 4.3

Part II

2. Information on questions and answers

2.1 Question paper I and information on answers to paper I

2.1.1 Structure of Paper I

Time is 02 hours. Total mark is 100.

- This question paper consists of 50 multiple choice questions each with five options. For each question, candidates were expected to select the correct or the most suitable option from the options (1), (2), (3), (4) and (5).
- Responding to all the questions is expected.

2.1.2 Paper I

- Green light of wave length 4.42×10^{-7} m is observed in the emission spectrum of hydrogen. The energy of one photon of this green light is
 (1) 4.5×10^{-19} kJ (2) 2×10^{-19} kJ (3) 1.5×10^{-19} kJ
 (4) 4.5×10^{-22} kJ (5) 19.9×10^{-26} kJ
- Which one of the following atoms in its gaseous state will liberate the largest amount of energy when it gains an electron?
 (1) S (2) P (3) Na (4) Mg (5) Ne

- What is the IUPAC name of the compound X?

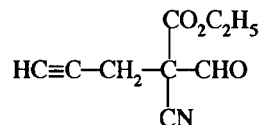

[X]

- ethyl 2-formyl-2-nitrile-4-pentynoate (2) 2-cyano-2-ethoxycarbonyl-4-pentynal
 (3) 2-ethoxycarbonyl-2-nitrile-4-pentynal (4) ethyl-2-cyano-2-formyl-4-pentynoate
 (5) ethyl 2-cyano-2-formyl-4-pentynoate
- Which of the following statements regarding sizes of ions formed by *s* and *p* block elements is false?
 (1) Cations are always smaller than their neutral atoms.
 (2) Anions are always larger than their neutral atoms.
 (3) The size of cations decreases from left to right across a period.
 (4) The size of anions increases from left to right across a period.
 (5) The size of anions formed by elements of second period are larger than cations formed by elements of third period.
- The sets of quantum numbers associated with the last two electrons of an atom in an element are $(3, 0, 0, +\frac{1}{2})$ and $(3, 0, 0, -\frac{1}{2})$. The element is
 (1) Li (2) Na (3) Mg (4) Al (5) K
- A 0.60 g sample of KIO_3 was dissolved in water and excess KI was added to it. The minimum amount of 3.0 mol dm^{-3} HCl required to completely convert KIO_3 to I_3^- is, (O = 16, K = 39, I = 127)
 (1) 1.0 cm^3 (2) 4.7 cm^3 (3) 5.6 cm^3 (4) 10.2 cm^3 (5) 33.6 cm^3
- At 25°C , the solubility product, K_{sp} of $\text{MnS}(\text{s})$ is $5.0 \times 10^{-15} \text{ mol}^2 \text{ dm}^{-6}$. The acid dissociation constants K_1 and K_2 for $\text{H}_2\text{S}(\text{aq})$ are $1.0 \times 10^{-7} \text{ mol dm}^{-3}$ and $1.0 \times 10^{-13} \text{ mol dm}^{-3}$ respectively. The equilibrium constant, K_c for the reaction, $\text{MnS}(\text{s}) + 2\text{H}^+(\text{aq}) \rightleftharpoons \text{Mn}^{2+}(\text{aq}) + \text{H}_2\text{S}(\text{aq})$ is
 (1) 2.0×10^{-16} (2) 5.0×10^{-8} (3) 20 (4) 5.0×10^5 (5) 2.0×10^7
- An organic compound A contains 39.97% of C, 6.73% of H and 53.30% of O, by weight. What is the empirical formula of A? (H = 1, C = 12, O = 16)
 (1) $\text{C}_6\text{H}_8\text{O}_2$ (2) $\text{C}_2\text{H}_4\text{O}_2$ (3) $\text{C}_3\text{H}_7\text{O}_3$ (4) $\text{C}_3\text{H}_6\text{O}_3$ (5) CH_2O
- Which of the following statements is false with regard to the chemistry of Lithium (Li) and its compounds?
 (1) Lithium reacts with oxygen gas to give Li_2O .
 (2) Lithium has the highest melting point among the group I metals.
 (3) The basicity of LiOH is less than that of NaOH .
 (4) Li_2CO_3 has the lowest thermal stability among the group I carbonates.
 (5) LiCl gives a blue colour when subjected to the flame test.
- The oxidation states of N^\oplus and N^\ominus in the most stable Lewis structure of the F_2NNO molecule respectively are (skeleton, $\text{F}-\overset{\text{F}}{\underset{\text{O}}{\text{N}}}-\text{N}-\text{O}$)
 (1) +2 and +2 (2) +1 and +3 (3) +2 and +3 (4) +1 and +2 (5) +3 and +1

11. Consider the reaction, $\text{CH}_4(\text{g}) + \text{CO}_2(\text{g}) \rightleftharpoons 2\text{CO}(\text{g}) + 2\text{H}_2(\text{g})$.
When 0.60 mol of $\text{CH}_4(\text{g})$ and 1.00 mol of $\text{CO}_2(\text{g})$ were introduced into a closed rigid container of volume 1.00 dm^3 at 25 °C and the system was allowed to reach equilibrium, 0.40 mol of $\text{CO}(\text{g})$ was formed. The value of the equilibrium constant, K_c ($\text{mol}^2 \text{dm}^{-6}$) for the reaction is
(1) 0.04 (2) 0.08 (3) 0.67 (4) 1.20 (5) 8.00
12. The chemical formula of diamminebromidodicarbonylhydridocobalt(III) chloride according to IUPAC rules is
(1) $[\text{Co}(\text{CO})_2\text{BrH}(\text{NH}_3)_2]\text{Cl}$ (2) $[\text{CoBr}(\text{CO})_2(\text{NH}_3)_2\text{H}]\text{Cl}$
(3) $[\text{Co}(\text{NH}_3)_2\text{Br}(\text{CO})_2\text{H}]\text{Cl}$ (4) $[\text{CoBr}(\text{CO})_2\text{H}(\text{NH}_3)_2]\text{Cl}$
(5) $[\text{CoHBr}(\text{CO})_2(\text{NH}_3)_2]\text{Cl}$
13. The following procedure was used to determine the sulphur content in a coal sample. A coal sample of mass 1.60 g was burned in oxygen gas. The SO_2 gas formed was collected in a solution of H_2O_2 . This solution was then titrated with 0.10 mol dm^{-3} NaOH. The volume of NaOH required to reach the end point was 20.0 cm^3 . The percentage of sulphur in the coal sample is ($S = 32$)
(1) 1.0 (2) 2.0 (3) 4.0 (4) 6.0 (5) 8.0

14. Combustion of ethylene, $\text{C}_2\text{H}_4(\text{g})$ is shown in the following reaction.

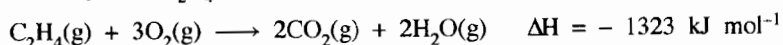

What is the value of ΔH (in kJ mol^{-1}) if the combustion produces water in the liquid state, $\text{H}_2\text{O}(\text{l})$ rather than water in the gaseous state, $\text{H}_2\text{O}(\text{g})$? (ΔH for $\text{H}_2\text{O}(\text{g}) \longrightarrow \text{H}_2\text{O}(\text{l})$ is -44 kJ mol^{-1})

- (1) -1235 (2) -1279 (3) -1323 (4) -1367 (5) -1411
15. The vapour pressure of benzene at 25 °C is 12.5 kPa. When an unknown non-volatile substance was dissolved in 100 cm^3 of benzene at this temperature, the vapour pressure of the solution was found to be 11.25 kPa. The mole fraction of the unknown substance in the above solution is
(1) 0.05 (2) 0.10 (3) 0.50 (4) 0.90 (5) 0.95
16. A buffer solution can be prepared by mixing a weak acid ($K_a = 4.0 \times 10^{-7} \text{ mol dm}^{-3}$) and a strong base. The ratio of the concentrations of acid to base (acid : base) needed to prepare a buffer solution at $\text{pH} = 6$ is
(1) 1 : 1 (2) 2 : 1 (3) 2 : 5 (4) 5 : 1 (5) 5 : 2

17.

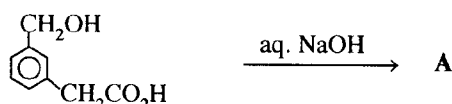

The major product A obtained from the reaction given above is

- (1)
- (2)
- (3)
- (4)
- (5)

18. The rate law for the reaction $\text{NO}_2(\text{g}) + \text{CO}(\text{g}) \longrightarrow \text{NO}(\text{g}) + \text{CO}_2(\text{g})$ is, $\text{Rate} = k[\text{NO}_2]^2$. If a small amount of $\text{CO}(\text{g})$ is introduced to a closed rigid container in which this reaction is taking place at a given temperature, which of the following statements is **true** regarding the changes that would take place?
- (1) Both k and reaction rate increase.
 - (2) Both k and reaction rate remain unchanged.
 - (3) Both k and reaction rate decrease.
 - (4) k increases and reaction rate remains unchanged.
 - (5) k remains unchanged and reaction rate increases.

19. At 25 °C, given that.

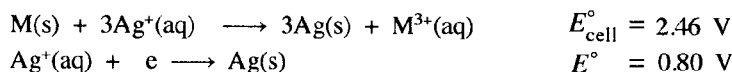

The standard reduction potential for the half-reaction, $\text{M}^{3+}(\text{aq}) + 3\text{e} \longrightarrow \text{M}(\text{s})$ at 25 °C is

- (1) -1.66 V
 - (2) -0.06 V
 - (3) 0.06 V
 - (4) 1.66 V
 - (5) 3.26 V
20. How many resonance structures can be drawn for the molecule N_2O_3 ? (skeleton, $\text{O}-\overset{\text{O}}{\text{N}}-\text{N}-\text{O}$)
- (1) 2
 - (2) 3
 - (3) 4
 - (4) 5
 - (5) 6
21. Which of the following statements is **true** with regard to transition metals and their compounds?
- (1) The electronic configuration of copper is $1s^2 2s^2 2p^6 3s^2 3p^6 3d^{10}$.
 - (2) All elements that have d -electrons are 'transition elements'.
 - (3) The electronic configuration of Ti in TiO_2 is the same as that of Sc in ScCl_3 .
 - (4) Acidity of the oxides of a given transition metal decreases with increase in oxidation state of the metal ion.
 - (5) Transition metals in the $3d$ series can have the quantum number $m_l = \pm 3$.

22. The equilibrium $\text{PCl}_3(\text{g}) + 3\text{NH}_3(\text{g}) \rightleftharpoons \text{P}(\text{NH}_2)_3(\text{g}) + 3\text{HCl}(\text{g})$ exists in a closed container at a constant temperature. If the volume of the container is increased by keeping the temperature constant, which of the following is **true** regarding the changes that could take place in the rates of forward and reverse reactions?

Forward reaction	Reverse reaction
(1) increases	decreases
(2) decreases	increases
(3) decreases	decreases
(4) increases	increases
(5) no change	no change

23. When solid ammonium chloride, $\text{NH}_4\text{Cl}(\text{s})$ is dissolved in water at 25 °C, the temperature of the solution decreases. Which of the following is **true** of ΔH° and ΔS° for the process?

ΔH°	ΔS°
(1) positive	positive
(2) positive	negative
(3) positive	zero
(4) negative	positive
(5) negative	negative

24. Which of the following statements is **false** regarding $3d$ transition metals and their compounds?
- (1) Oxides of some metals are amphoteric.
 - (2) Some metals and metal oxides are used in industry as catalysts.
 - (3) Electronegativity of $3d$ transition metals is higher than $4s$ metals.
 - (4) Only one element shows the oxidation state of +7.
 - (5) Oxoions such as MnO_4^- , $\text{Cr}_2\text{O}_7^{2-}$ are resistant to reduction.

25.

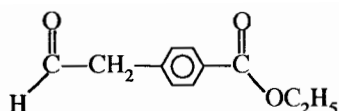

The major product obtained, when the compound above is reacted with excess CH_3MgBr , and then hydrolyzed is

- (1)
- (2)
- (3)
- (4)
- (5)

26.

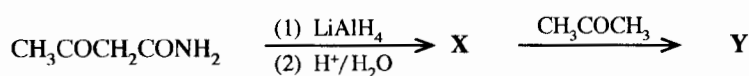

In the reaction scheme given above, the structures of **X** and **Y** respectively are

- (1)
- (2)
- (3)
- (4)
- (5)

27. Which of the following statements is **false** with regard to NH_3 ?

- (1) NH_3 can act only as a base.
- (2) NH_3 burns in oxygen to give N_2 gas.
- (3) NH_3 gives a brown colour with Nessler's reagent.
- (4) NH_3 reacts with Li to give Li_3N and H_2 gas.
- (5) NH_3 has a bond angle less than $109^\circ 28'$ but greater than that in NF_3 .

28. An electrochemical cell was constructed using $\text{Zn}^{2+}(\text{aq})/\text{Zn}(\text{s})$ and $\text{Sn}^{2+}(\text{aq})/\text{Sn}(\text{s})$ electrodes. Which of the following statements correctly describes the operation of the cell?

$$E^\circ_{\text{Zn}^{2+}(\text{aq})/\text{Zn}(\text{s})} = -0.76 \text{ V}, \quad E^\circ_{\text{Sn}^{2+}(\text{aq})/\text{Sn}(\text{s})} = -0.14 \text{ V}$$

- (1) Zn electrode is the cathode, Zn is oxidized, electrons flow from Sn to Zn.
- (2) Zn electrode is the cathode, Sn is oxidized, electrons flow from Sn to Zn.
- (3) Sn electrode is the anode, $\text{Zn}^{2+}(\text{aq})$ is reduced, electrons flow from Zn to Sn.
- (4) Zn electrode is the anode, Zn is oxidized, electrons flow from Zn to Sn.
- (5) Zn electrode is the anode, $\text{Sn}^{2+}(\text{aq})$ is reduced, electrons flow from Sn to Zn.

29. Which one of the following statements about $\text{C}_6\text{H}_5\text{NH}_2$ is **false**?

- (1) Reacts with CH_3COCl to form an amide.
- (2) Evolves ammonia when heated with aqueous NaOH .
- (3) Reacts with bromine water to give a white precipitate.
- (4) Gives a phenol when reacted with nitrous acid.
- (5) Less basic than $\text{C}_6\text{H}_5\text{CH}_2\text{NH}_2$.

30. Four saturated solutions of silver acetate in contact with $\text{CH}_3\text{COOAg}(s)$ are placed in four beakers. How does the solubility of silver acetate change, when the following solutions are added separately to each of the beakers?



	CH_3COONa	dil. HNO_3	NH_4OH	AgNO_3
(1)	increases	increases	increases	increases
(2)	decreases	decreases	decreases	decreases
(3)	decreases	increases	increases	decreases
(4)	decreases	increases	decreases	decreases
(5)	decreases	decreases	increases	decreases

- For each of the questions 31 to 40, one or more responses out of the four responses (a), (b), (c) and (d) given is/are correct. Select the correct response/responses. In accordance with the instructions given on your answer sheet, mark

- (1) if only (a) and (b) are correct.
- (2) if only (b) and (c) are correct.
- (3) if only (c) and (d) are correct.
- (4) if only (d) and (a) are correct.
- (5) if **any other** number or combination of responses is correct.

Summary of above Instructions

(1)	(2)	(3)	(4)	(5)
Only (a) and (b) are correct	Only (b) and (c) are correct	Only (c) and (d) are correct	Only (d) and (a) are correct	Any other number or combination of responses is correct

31. Consider the reaction given below.

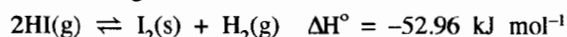

Which of the following statements is/are **correct** when the reaction takes place in a closed container?

- (a) Increasing the temperature and decreasing the pressure drives the equilibrium to the right.
 - (b) Increasing the temperature and decreasing the pressure drives the equilibrium to the left.
 - (c) Decreasing the temperature and increasing the pressure drives the equilibrium to the right.
 - (d) Decreasing the temperature and increasing the pressure drives the equilibrium to the left.
32. Which of the following statements is/are **true** regarding the molecule $\text{CH}_2=\text{CHCHO}$?
- (a) All three carbon atoms are sp^2 hybridized.
 - (b) All three carbon atoms lie in a straight line.
 - (c) All three carbon atoms do not lie in the same plane.
 - (d) All three carbon atoms lie in the same plane.
33. Some of the reactions associated with the Solvay process are
- (a) $\text{CaCO}_3 \xrightarrow{\Delta} \text{CaO} + \text{CO}_2$
 - (b) $\text{NaCl} + \text{NH}_3 + \text{H}_2\text{O} + \text{CO}_2 \longrightarrow \text{NaHCO}_3 + \text{NH}_4\text{Cl}$
 - (c) $\text{Na}_2\text{CO}_3 + \text{CO}_2 + \text{H}_2\text{O} \longrightarrow 2\text{NaHCO}_3$
 - (d) $\text{Ca}(\text{OH})_2 + 2\text{NH}_4\text{Cl} \longrightarrow \text{CaCl}_2 + 2\text{NH}_4\text{OH}$
34. Which of the following statements is/are always **true** regarding the rate of an elementary reaction?
- (a) The rate can be increased by increasing temperature.
 - (b) The rate can be increased by removing the products from the reaction medium.
 - (c) The rate of the reaction depends on the rate of the slowest step.
 - (d) Rate of the reaction can be increased by making $\Delta G < 0$.
35. Which of the following statements is/are **true** regarding 4-pentenal?
- (a) Shows geometric isomerism.
 - (b) The compound obtained when reacted with HBr does not show optical isomerism.
 - (c) The compound obtained when reacted with HBr shows optical isomerism.
 - (d) The compound obtained when reacted with CH_3MgBr shows optical isomerism.

36. Which of the following statements is/are **false** with regard to nitric acid?
- Pure nitric acid is a light yellow liquid.
 - All N—O bond lengths in nitric acid are equal.
 - Nitric acid cannot act as a reducing agent.
 - It is used in the manufacture of an important fertilizer, ammonium nitrate.
37. C(s) reacts with O₂(g) to produce 0.40 mol of CO₂(g), with the release of 40 kJ of heat. Which of the following statements is/are **true** for the above system? (C = 12, O = 16)
- 100 kJ of heat is required to decompose one mole of CO₂(g) into C(s) and O₂(g).
 - 25 kJ of heat is required to form 11 g of CO₂(g).
 - Sum of enthalpies of products is less than the sum of enthalpies of reactants.
 - Sum of enthalpies of products is greater than the sum of enthalpies of reactants.
38. Which of the following statements is/are **true** for a balanced chemical equation of an elementary reaction?
- The order of reaction is the same as molecularity.
 - The order of reaction is less than the molecularity.
 - The order of reaction is higher than the molecularity.
 - Molecularity cannot be zero.
39. Which of the following statements is/are **true** regarding the molecule given below?

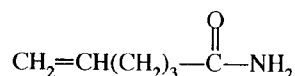

- Decolourizes bromine water.
 - Liberates ammonia when warmed with an aqueous NaOH solution.
 - Gives an orange coloured precipitate with 2,4-DNP reagent.
 - Gives a primary amine when treated with NaBH₄.
40. Consider the compounds given below.
- | | | |
|--|---|--------------------------------------|
| (A) HCHO | (B) NH ₂ CONH ₂ | (C) C ₆ H ₅ OH |
| (D) HO ₂ C(CH ₂) ₄ CO ₂ H | (E) H ₂ N(CH ₂) ₆ NH ₂ | |
- Which of the pairs given below will produce thermosetting polymers when reacted under the appropriate conditions?
- A and B
 - A and C
 - C and D
 - D and E

- In question Nos. 41 to 50, two statements are given in respect of each question. From the Table given below, select the response out of the responses (1), (2), (3), (4) and (5) that **best** fits the two statements and mark appropriately on your answer sheet.

Response	First Statement	Second Statement
(1)	True	True, and correctly explains the first statement.
(2)	True	True, but does not explain the first statement correctly.
(3)	True	False
(4)	False	True
(5)	False	False

	First Statement	Second Statement
41.	Sucrose when treated with concentrated H ₂ SO ₄ gives a black mass.	Concentrated H ₂ SO ₄ is a strong oxidizing agent.
42.	In the addition reaction between CH ₃ CH=CH ₂ and HX, the CH ₃ CH ₂ CH ₂ [⊕] carbocation is formed easily as an intermediate.	Alkyl groups attached to a positively charged carbon atom release electrons through C—C, σ-bonds towards the positively charged carbon and increase the stability of the carbocation.

43.	The average molecular speed of $\text{H}_2(\text{g})$ at $80\text{ }^\circ\text{C}$ is lower than that of $\text{N}_2(\text{g})$ at $40\text{ }^\circ\text{C}$.	Average molecular speed is directly proportional to the square root of temperature and inversely proportional to the square root of molar mass.
44.	Reactivity of alkali metals with water increases on going down the group.	Strong metallic bonds are formed when the size of the metal atom increases.
45.	$\text{CH}_3\text{C}\equiv\text{CH}$ gives a red precipitate when treated with ammoniacal Cu_2Cl_2 .	The acidic terminal hydrogen in alkynes can be displaced by metals.
46.	All spontaneous reactions are exothermic.	For any reaction $\Delta G = \Delta H + T\Delta S$
47.	The reaction between $\text{N}_2(\text{g})$ and $\text{H}_2(\text{g})$ to produce $\text{NH}_3(\text{g})$ is endothermic.	$\text{NH}_3(\text{g})$ is used in the synthesis of nitric acid and urea.
48.	Mirror images of bromochloromethane are enantiomers.	Enantiomers are non superimposable mirror images of each other.
49.	The solubility of barium oxalate, $\text{BaC}_2\text{O}_4(\text{s})$ is less in acidic aqueous medium than in water.	The conjugate acid of $\text{C}_2\text{O}_4^{2-}$ is the weak acid $\text{H}_2\text{C}_2\text{O}_4$.
50.	Enzymes present in root nodules of certain plants are capable of fixing N_2 .	N_2 molecule is unreactive mainly because of the presence of the $\text{N}-\text{N}$ triple bond.

2.1.3 Expected answers and the marking scheme for Paper I

Question No.	Answer	Question No.	Answer
01.	4	26.	2
02.	1	27.	1
03.	5	28.	4
04.	4	29.	2
05.	3	30.	3
06.	3	31.	2
07.	4	32.	4
08.	5	33.	1 and 5
09.	5	34.	5
10.	1	35.	3
11.	2	36.	1
12.	4	37.	5
13.	2	38.	4
14.	5	39.	1
15.	2	40.	1
16.	All	41.	2
17.	3	42.	4
18.	2	43.	5
19.	1	44.	3
20.	3	45.	1, 2 and 4
21.	3	46.	5
22.	3	47.	4
23.	1	48.	4
24.	5	49.	5
25.	5	50.	2 and 4

Each correct answer carries 02 marks, amounting the total to 100.

2.1.4 Observations on the responses to Paper I (by subject area) :

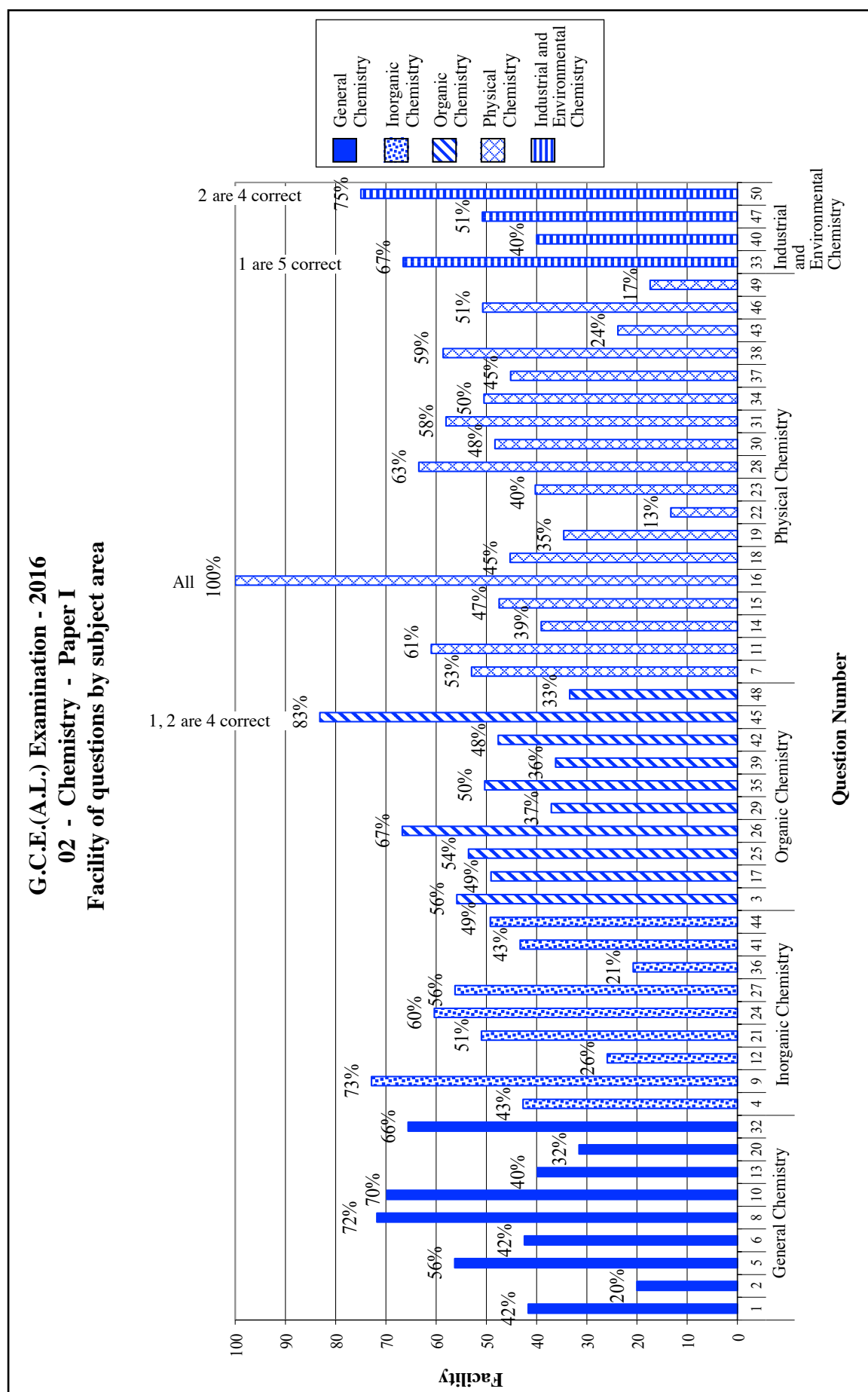

Subject area	The question of highest facility and its facility	The question of lowest facility and its facility
General Chemistry	8 (72%)	2 (20%)
Physical Chemistry	28 (63%)	22 (13%)
Organic Chemistry	26 (67%)	48 (33%)
Inorganic Chemistry	9 (73%)	36 (21%)
Industrial and Environmental Chemistry	47 (51%)	40 (40%)

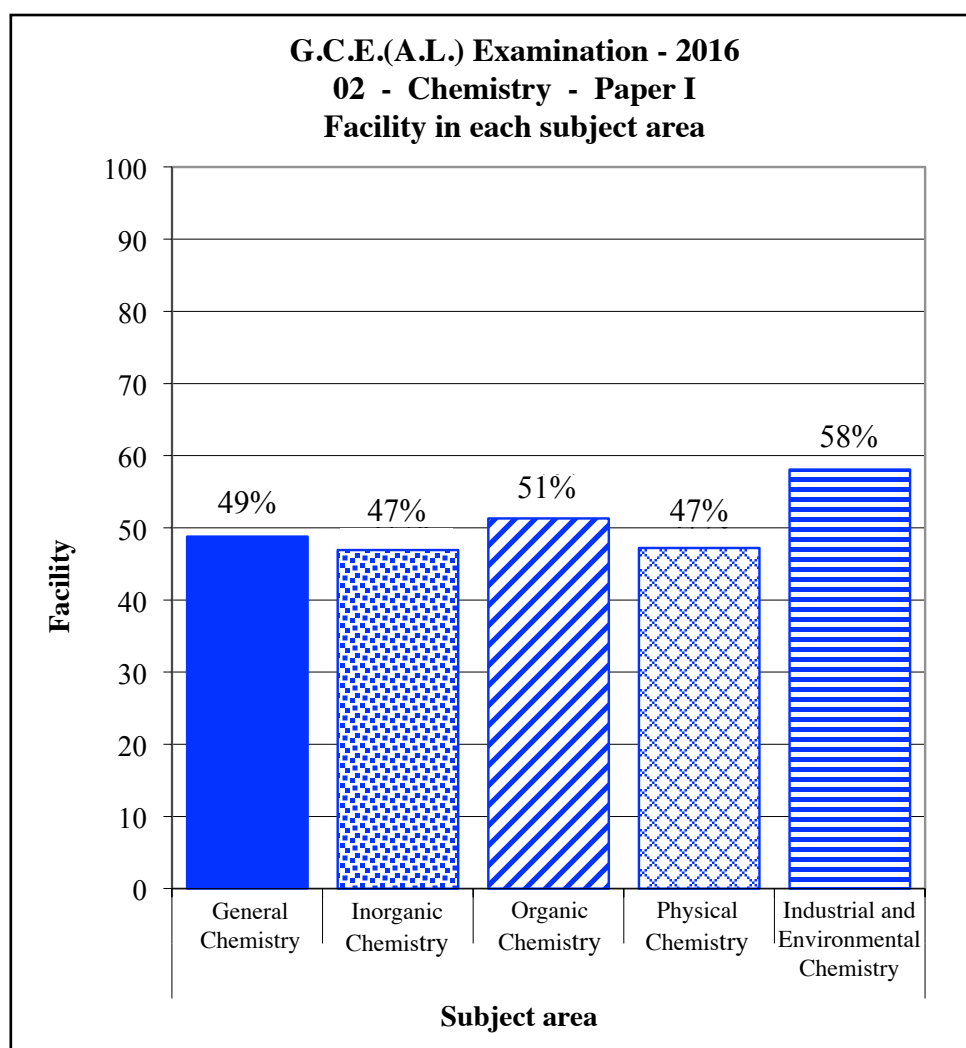

Out of the five areas of the subject used to set the question paper, the highest facility has been shown for industrial chemistry and environmental chemistry. Its facility is 58%. Least facility has been shown for inorganic chemistry and physical chemistry. Its facility is 47%.

But, except the two areas industrial chemistry and environmental chemistry, for the questions given in remaining four areas are shown approximately the same facility by the candidates.

2.1.5 Responses to the options in Paper I - as a percentage

Question Number	Correct Answer	Percentage of students selecting each option				
		1	2	3	4	5
1	4	43%	5%	8%	42%	2%
2	1	20%	9%	29%	9%	33%
3	5	6%	13%	4%	21%	56%
4	4	3%	5%	9%	43%	40%
5	3	4%	24%	56%	11%	5%
6	3	9%	21%	43%	19%	8%
7	4	9%	23%	7%	53%	8%
8	5	3%	6%	10%	9%	72%
9	5	3%	10%	5%	9%	73%
10	1	70%	6%	9%	7%	8%
11	2	11%	61%	14%	10%	4%
12	4	6%	16%	34%	26%	18%
13	2	6%	40%	29%	16%	9%
14	5	13%	17%	5%	26%	39%
15	2	9%	48%	16%	20%	7%
16	All	11%	19%	26%	17%	27%
17	3	23%	16%	49%	5%	7%
18	2	8%	45%	7%	9%	31%
19	1	35%	16%	12%	26%	11%
20	3	8%	26%	32%	21%	13%
21	3	4%	8%	51%	20%	17%
22	3	8%	12%	13%	7%	60%
23	1	40%	26%	9%	18%	7%
24	5	4%	3%	24%	9%	60%
25	5	8%	13%	6%	19%	54%
26	2	10%	67%	10%	5%	8%
27	1	56%	13%	6%	9%	16%
28	4	6%	9%	9%	64%	12%
29	2	14%	37%	16%	15%	18%
30	3	7%	7%	49%	26%	11%
31	2	3%	58%	4%	22%	13%
32	4	6%	5%	2%	66%	21%
33	1 and 5	29%	16%	7%	10%	38%
34	5	18%	10%	8%	13%	51%
35	3	10%	5%	51%	9%	25%
36	1	21%	30%	11%	10%	28%
37	5	11%	17%	8%	18%	46%
38	4	4%	5%	11%	59%	21%
39	1	37%	11%	8%	16%	28%
40	1	40%	13%	13%	15%	19%
41	2	30%	44%	9%	14%	3%
42	4	17%	12%	9%	48%	14%
43	5	13%	6%	7%	50%	24%
44	3	15%	23%	49%	7%	6%
45	1, 2 and 4	47%	18%	9%	19%	7%
46	5	5%	9%	17%	18%	51%
47	4	4%	31%	7%	51%	7%
48	4	22%	8%	16%	34%	20%
49	5	17%	15%	14%	36%	18%
50	2 and 4	10%	52%	10%	23%	5%

* Under each question, the percentage of students, selecting the correct option is shaded.

2.1.6 Overall observations, conclusions and suggestions regarding the answers to Paper I :

Out of the first 30 questions the percentage of giving the correct response for 9 questions (2, 12, 13, 14, 19, 20, 22, 23 and 29) is less than 40%. Out of the questions 31 – 40. The number of questions for which the percentage of correct responses equal or below 40% are four. (33, 36, 39 and 40). Out of the questions 41 – 50, there are 3 questions (43, 48 and 49) to which less than 40% percentage has given the correct response.

The question numbers to which the less than 40% correct answers obtained are given below with the relevant subject areas.

Subject area	Total number of questions	Question number	Number of question
Physical Chemistry	18	14, 19, 22, 23, 43, 49	06
General Chemistry	09	2, 13, 20	03
Organic Chemistry	10	29, 39, 48	03
Industrial and Environmental Chemistry	04	33, 40	02
Inorganic Chemistry	09	12, 36	02

Out of the 18 questions regarding physical chemistry, less than 40% facility has been shown for 6 questions. When solving the problems in physical chemistry, it is needed to consider about logical thinking, memorizing equations, considering the stoichiometric relationships, using the correct units and correct mathematical operations other than the appropriate theories or concepts. Therefore it is also important to develop those skills in the candidates during the teaching and learning process.

In the question number 2 which belongs to general chemistry, the correct response (1) has been selected by only 20%. But the false responses (3) and (5) have been selected as the correct response by 29% and 33% respectively.

As electron affinity or ability of gaining electrons is dependent on the nature and the electron configuration of an atom, energy can be released or gained in that process. Hence, for releasing large amount of energy a stable configuration should be obtained by gaining an electron and it should be an electronegative atom. As those facts are not realized correctly, correct response has not been selected by the majority. Even in last few years the facility shown by the candidates in the questions related to this concept was relatively low, more attention should be paid on it in the teaching and learning process.

For question numbers 3 to 10, the correct response has been selected by more than 40%.

Question number 12 which was given under the area of inorganic chemistry, the percentage of selecting the correct response is 26%. When writing the chemical formula for a complex compound with given IUPAC name, the sequence of the ligand groups should be given in the English alphabetical order of their valence atoms. Reason for low facility level is due to the unawareness of that concept.

The percentage of selecting the correct response (1) for the question number 19 is 35 %. The question was prepared by using simple concepts in electro-chemistry. The candidates should develop the required skills and practice more exercises in identifying the anodes and cathodes of the cell reactions and calculating the standard electrode potentials of the electrodes.

The percentage of selecting the correct response for the question number 20 is 32 %. Though the question contains an easy subject matter, it has been shown even in the previous years that the facility level is low. As a suitable remedy, needs to develop the skills of drawing resonance structures methodically in accordance with the basic rules of drawing Lewis structures.

Question 22 in which the least facility (13 %) has been shown, belongs to the area of physical chemistry. Though its correct response is 3, the majority (60 %) of the candidates have selected the 5th response. A closed vessel consists of an equilibrium system, in which a reversible reaction takes place, if the volume of the vessel is increased at a constant temperature, the pressure inside the system decreases. Then as the number of collisions occurs in a unit time decreases due to the lowering of the pressure, the rates of the forward and backward reactions decrease. If this theory has been considered, the correct response could have been selected easily.

Question 39 is from organic chemistry. Its correct response (1) has been selected by 37% of the candidates. But the 5th response has been selected as the correct response by 28%.

The candidates should be emphasized that the $\left(-\overset{\text{O}}{\parallel}{\text{C}}-\right)$ group in amides $\left(-\overset{\text{O}}{\parallel}{\text{C}}-\text{NH}_2\right)$ do not participate in the characteristic reactions shown by aldehydes and ketones. These weaknesses can be avoided by involving in the prescribed practical activities.

Facility of the correct response (5) in question 49 is 18%. But 36% has selected the response (4). When selecting the correct response, it is important for the candidates to know that in accordance with the dissociation of the dibasic acid $\text{H}_2\text{C}_2\text{O}_4$, the conjugate acid of $\text{C}_2\text{O}_4^{2-}$ ion is HC_2O_4^- .

In answering the questions 31 to 50, the skill of analysis and synthesis is well used. Reading the questions properly and understanding the subject matter well, but when it is difficult to answer, focusing on selecting a false response without logically thinking, is the reason for low facility level shown in these questions.

Some common shortcomings done by the candidates when answering the multiple choice questions are,

1. Not understanding the basic subject matter clearly / leaving out the facts.
2. Not reading and understanding the questions well.
3. Not reading the question completely.
4. Concerning much about the time making the questions difficult to be solved.
5. Not applying the principles / theories in chemistry to the relevant position.
6. Lack of pre knowledge in the way of answering a multiple choice question.

By avoiding those defects, this question paper can be answered successfully.

2.2 Paper II and information on answers

2.2.1 Structure of the Paper II

Time is 03 hours. Total mark is 100.

This paper consists of three parts **A, B** and **C**.

Part A – This contains **four structured essay** questions. All the questions should be answered. Each question carries 100 marks, so the total mark is 400.

Part B – This comprises **three essay** type questions of which **two** should be answered. Marks allocated for each question is 150. The total mark is 300.

Part C – This comprises **three essay** type questions of which **two** should be answered. Marks allocated for each question is 150. The total mark is 300.

Total mark for Paper II is $1000 \div 10 = 100$

2.2.2 Selection and facility of questions in Paper II

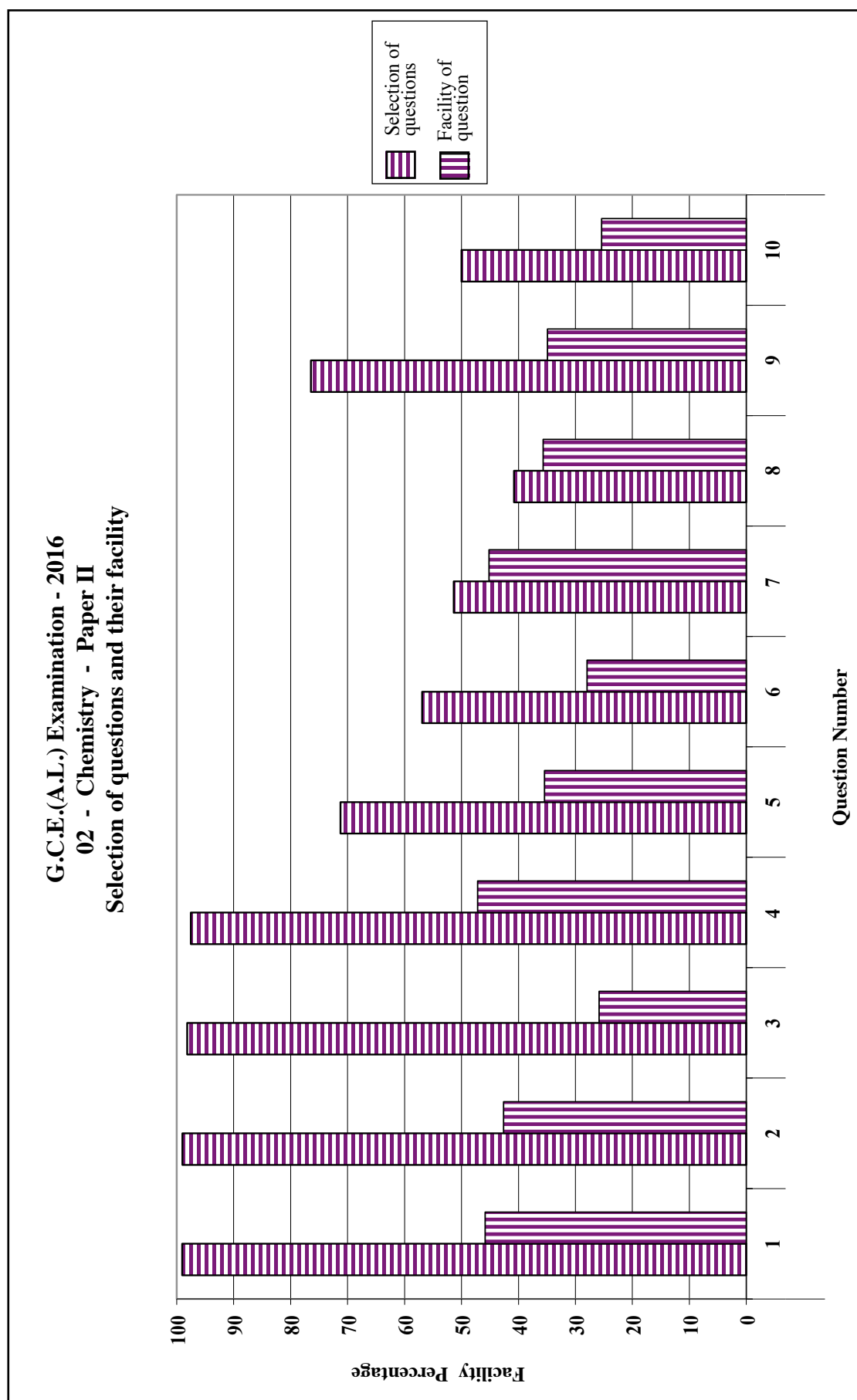

2.2.3 Expected answers, marking scheme and observations and conclusions related to paper II

★ The observations related to the answers for Paper II have been presented by the graphs 2, 3, 4.1, 4.2 and 4.3.

PART A – STRUCTURED ESSAY

Answer **all four** questions on this paper itself. (Each question carries **10** marks.)

Question 1

1. (a) You are provided with the following list of some *p*-block elements in the Periodic Table.

B	C	N	O	F	Ne
Al	Si	P	S	Cl	Ar

From the list,

- | | |
|--|------------------------|
| (i) identify the non-metallic element that forms a homoatomic covalent lattice of high hardness. | C |
| (ii) identify the element that exhibits the widest range of oxidation states. | N/S/P/Cl/C |
| (iii) identify the element that has the highest first ionization energy. | Ne |
| (iv) identify the element that exhibits amphoteric properties. | Al |
| (v) identify the element that has two gaseous allotropes. | O |
| (vi) identify the element that is considered to be the strongest oxidizing agent. | F |
| (04 × 6 = 24 marks) | |

Note : If more than one answer is given for a question, award zero marks for that question.

1(a) : 24 marks

(b) The following parts (i) to (v) are based on the molecule CN₄. It has the following skeleton.



(i) Assuming that N—N bond lengths are approximately equal, draw the **most acceptable** Lewis structure for this molecule.

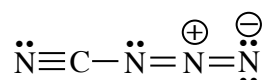

(10 marks)

(ii) Draw **three** resonance structures for this molecule (excluding the structure drawn in part (i) above).

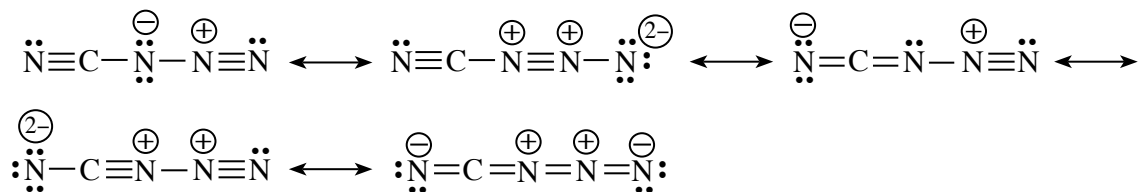

Note : Consider first three responses.

(05 × 3 = 15 marks)

- (iii) Based on the Lewis structure drawn in (i) above, state the following regarding the C and N atoms given in the table below.

- I. VSEPR pairs around the atom. II. electron pair geometry around the atom.
 III. shape around the atom. IV. hybridization of the atom.

The nitrogen atoms of CN_4 are numbered as follows:

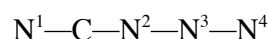

		C	N ²	N ³
I.	VSEPR pairs	2	3	2
II.	Electron pair geometry	Linear	trigonal planar	Linear
III.	Shape	Linear	Angular / V	Linear
IV.	Hybridization	<i>sp</i>	<i>sp</i> ²	<i>sp</i>

(01 × 12 = 12 marks)

- (iv) In the Lewis structure drawn in part (i) above, indicate whether N² or N³ has the **higher** electronegativity. Give reasons for your choice. [Numbering of atoms is as in part (iii).]

N³ > N² **or** N³ has higher electronegativity than N² (05)

N³ - *sp* and carries a positive charge **or** Oxidation state is +1 (01 + 01)

N² - *sp*² and carries zero charge **or** Oxidation state is -1 (01 + 01)

Higher the positive charge/higher the electronegativity/Higher the positive oxidation state (01)

Higher the *s*-character, higher the electronegativity (01)

- (v) Identify the atomic/hybrid orbitals involved in the formation of the following σ bonds in the Lewis structure drawn in part (i) above. [Numbering of atoms is as in part (iii).]

I. N¹-C N¹..... *sp* **or** *2p*....., C..... *sp*.....

II. C-N² C..... *sp*....., N²..... *sp*².....

III. N²-N³ N²..... *sp*²....., N³..... *sp*.....

IV. N³-N⁴ N³..... *sp*....., N⁴..... *sp*² **or** *2p*.....

(01 × 8 = 08 marks)

Note : Even if the Lewis structure drawn in (b)(i) is wrong, award marks for pair geometry in central atom/around the atom are given.

1(b) : 56 marks

- (c) State whether the following statements are **true** or **false**. (Reasons are **not** required.)

(i) SF₆ and OF₆ are both stable molecules. False.....

(ii) Although the electron pair geometry of SiCl₄, NCl₃ and SCl₂ is tetrahedral, their bond angles are different. True.....

(iii) The boiling point of Kr is greater than that of Xe. False.....

(iv) The solubility of group II sulphates decreases down the group primarily due to decrease in hydration enthalpy of the cations. True.....

(05 × 4 = 20 marks)

1(c) : 20 marks

Total for 1 : 100 marks

Overall observations, conclusions and suggestions regarding the answers to Question 1 :

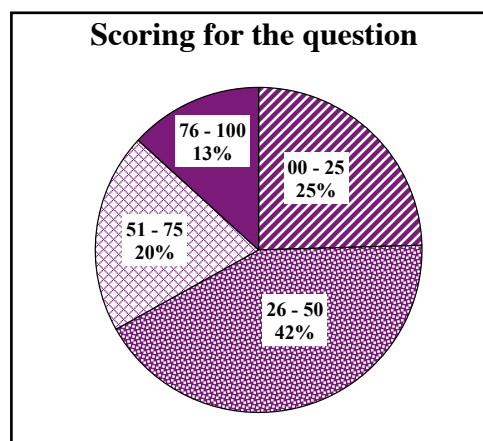

Though this question is compulsory, it is answered by 99 %. 100 marks are allocated for this question.

Out of it : in the interval 00 - 25 25%
in the interval 26 - 50 42%
in the interval 51 - 75 20%
in the interval 76 - 100 13%

have scored marks.

13 % have scored above 76 marks whereas 25 % of the candidates have scored 25 marks or below

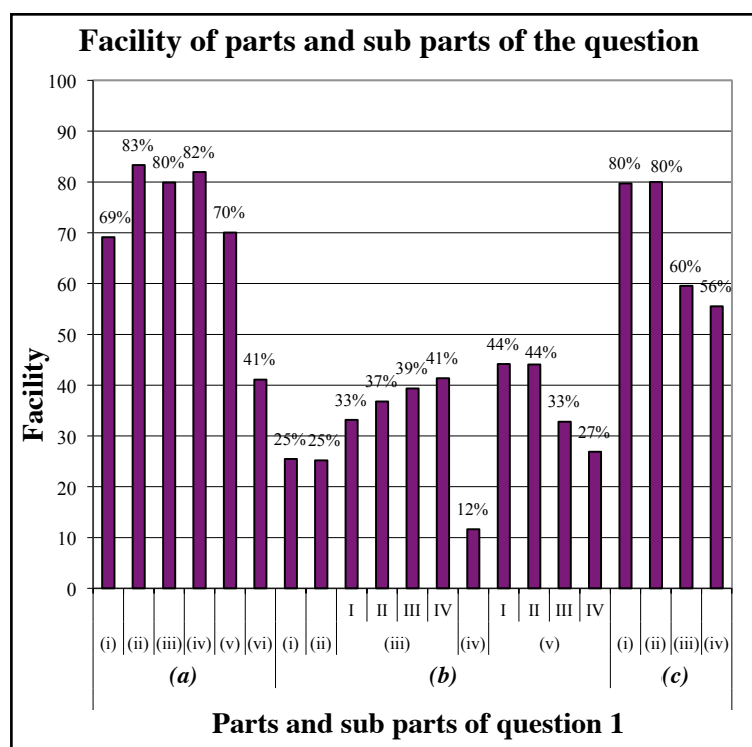

This question comprises 21 sub parts. Out of them 12 sub parts have been shown the competency 50% or less than that. The least competency has been shown by the sub part (b)(iv) and its competency is 12%.

Easiest sub part is (a)(ii) and its competency is 83%.

In (a)(i) the four facts high rigidity, homo-atomic nature, covalent nature, non metallic character should be considered but as the competency for this easy question is 69%, it is seen that all the relevant four facts have not been considered by the candidates. Its part (vi) is a very easy question. But F should be identified as the element with highest oxidizing nature. In this question least competency has been shown by (b)(iv). There are some reasons. One reason is there are no marks if part (i) is wrong. The strongest fact here which should be emphasized in the teaching – learning process is that higher the oxidation number and higher the s - character of the hybrid orbitals its electro-negativity increases.

Question 2

2. (a) **X** and **Y** are *s*-block elements of the Periodic Table. They react with water to form hydroxides. The hydroxide of **X** is more basic than that of **Y**. The hydroxide of **X** is used in the manufacture of baby soap. The hydroxide of **Y** is commonly used to identify the gas **Z** that is one of the main gases responsible for global warming.

(i) Identify **X** and **Y**.

K <u>or</u> potassium

Ca <u>or</u> calcium

(03 + 03)

(ii) Write the electronic configurations of **X** and **Y**.

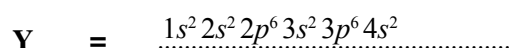
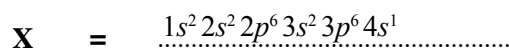

(03 + 03)

(iii) Write the colour of the flame given by salts of **X** and **Y** in the flame test.

X : lilac/violet/reddish-violet.....

Y : brick red/yellow-red/orange red

Note : Marks could be awarded for 'orange' colour

(03 + 03)

(iv) Indicate the relative magnitudes of the following in respect of **X** and **Y**.

I. Atomic size

$\boxed{X} > \boxed{Y}$

II. Density

$\boxed{Y} > \boxed{X}$

III. Melting point

$\boxed{Y} > \boxed{X}$

IV. First ionization energy

$\boxed{Y} > \boxed{X}$

(03 × 4)

Note : If one answer in (a)(i) is correct, award marks for the respective correct answers of (a)(ii) and (a)(iii). Award marks for (a)(iv) only if both **X** and **Y** are correctly identified.

If answer is given as **X** = KOH, **Y** = Ca(OH)₂ do not award marks for (a)(i) and (a)(iv). However, award marks for correct answers of (a)(ii) and (a)(iii).

(v) Identify **Z**.

.....CO₂.....

(03)

(vi) Using balanced chemical equations **only**, indicate how the hydroxide of **Y** could be used to identify **Z**.

Note: Indicate precipitates, if any, using “↓” and colours of precipitates/solutions used in the identification.

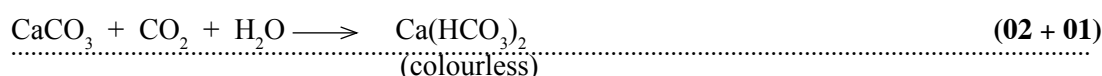
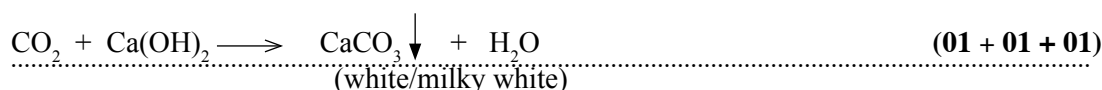

Note : If **Y** has been identified correctly, **Y** could be used instead of Ca.

(vii) A natural source of **Y** in which it is present as a carbonate is used as a raw material in the manufacture of a disinfectant.

I. Name the natural source. limestone/marble/oyster shells (03)

II. Identify the disinfectant. $\text{Ca(OCl)}_2 \cdot \text{Ca(OH)}_2 \cdot \text{CaCl}_2 \cdot 2\text{H}_2\text{O(s)}$ / Ca(OCl)_2 / Bleaching powder (03)

III. Write the steps in the manufacturing process of the disinfectant, using balanced chemical equations **only**.

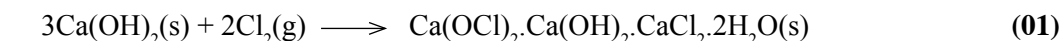

Note : Physical states are not required.

2(a) : 50 marks

(b) (i) Complete the reactions given below by selecting the appropriate solution from the given list and writing in the box.

List of solutions (not in order)

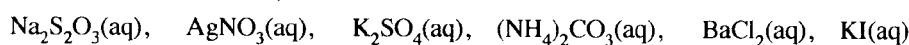

Note: A solution should be used **only once**.

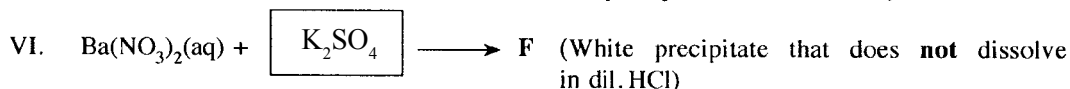
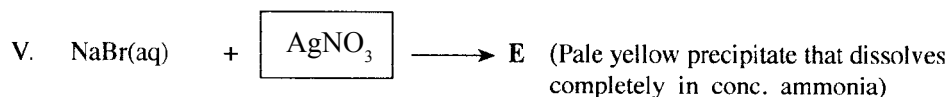
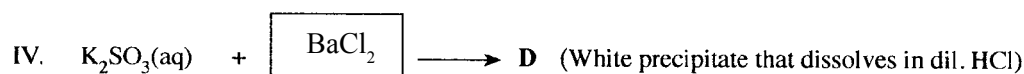
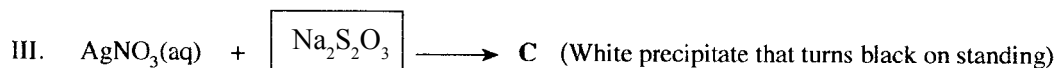
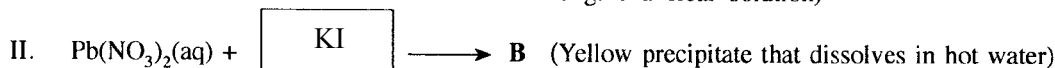
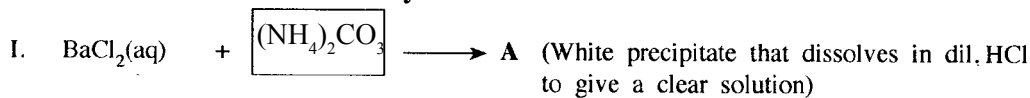

(04 × 6 = 24 marks)

(ii) Write the chemical formulae of the precipitates **A** to **F**.

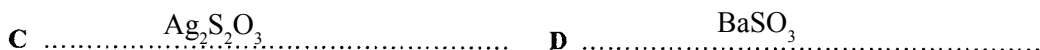
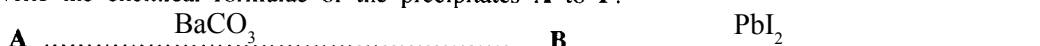

(03 × 6 = 18 marks)

(iii) Write balanced chemical equations for the dissolution of precipitates **A**, **D** and **E** in (b)(i) above.

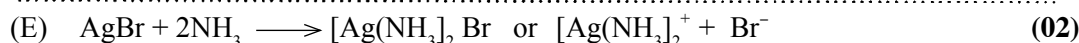
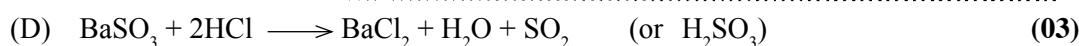

Note : Mark (b)(iii) independently.

2(b) : 50 marks

Total for 2 : 100 marks

Overall observations, conclusions and suggestions regarding the answers to Question 2 :

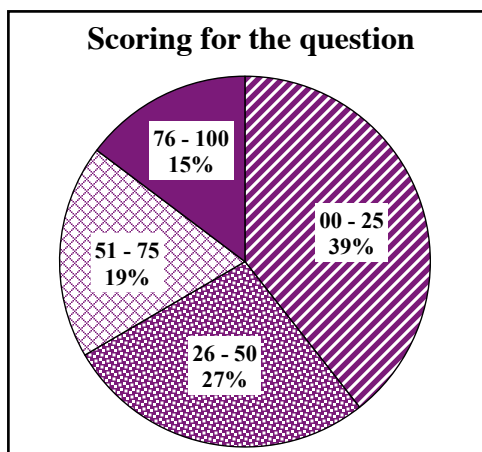

Though this question is compulsory, it is answered by 99 %.
100 marks are allocated for this question

Out of it : in the interval 00 - 25 25%
 in the interval 26 - 50 27%
 in the interval 51 - 75 19%
 in the interval 76 - 100 13%

have scored marks.

15% have scored above 76 marks whereas 39% of the candidates have scored 25 marks or below

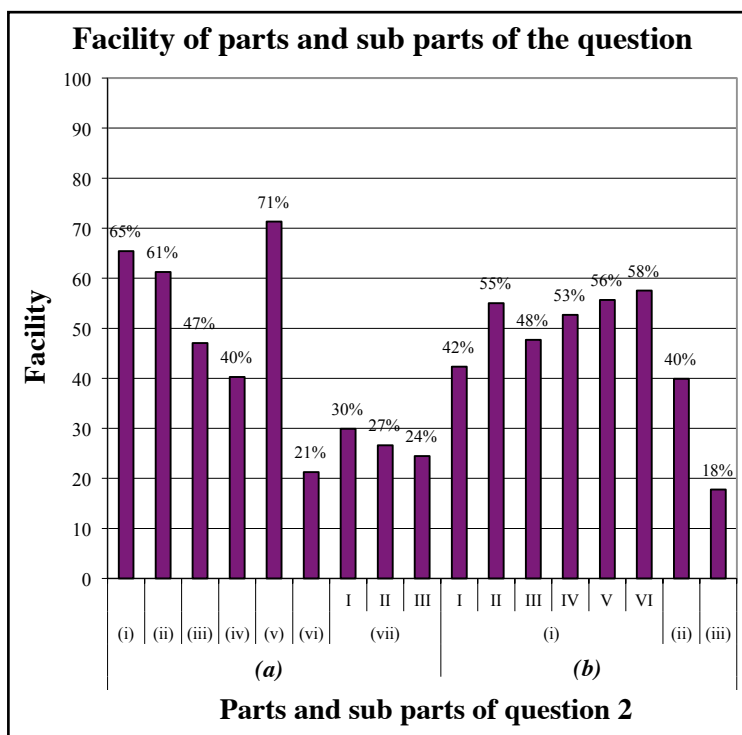

This question comprises 17 sub parts. Out of them there are ten parts with the facility 50% or less than that. The least facility has been shown by the sub part (b)(iii) and its facility is 18%.

Easiest sub part is (a)(v) and its facility is 71%.

As the correct answer for (a)(i) the name of the element should be written, but name of the hydroxide has been written by most.

Once again it should be emphasized the importance of reading the question and understanding it correctly. In the part (b)(iii) which has been shown the least facility, the equation for the dissolving of the precipitate should have been understood correctly.

In (a)(vii) I name of the resource is asked. There, name of the resource should be written. The formula should be given only if it is asked.

Containing of potassium compounds in baby soap is mentioned even in the ordinary level syllabus. Ordinary level syllabus should not be forgotten .

Question 3

3. (a) When 0.010 moles of gas A is placed in a 1.0 dm³ evacuated closed rigid container in the presence of a small amount of a solid catalyst, at 227 °C, it decomposes as shown below.



The concentration of A(g) was measured over time. The results are shown in the following graph.

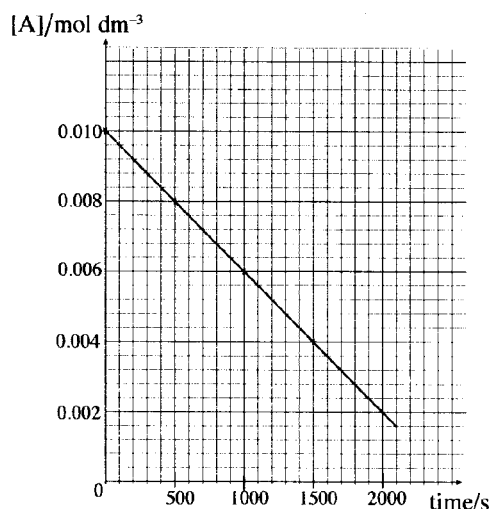

- (i) Taking the order and the rate constant of the reaction as **a** and **k**, respectively, write the rate expression for the above reaction.

Rate = $k[A]^a$ **or** (10)

$\left[-\frac{\Delta[A]}{\Delta t} = k[A]^a \text{ or } -\frac{d[A]}{dt} = k[A]^a \right]$ if (-) sign is not included do not award marks

- (ii) Giving reasons, determine the value of **a**.

Rate = $k[A]^0$ **or** order = $a = 0$ (10)

Rate = constant (gradient is constant) **or** Rate is independent of concentration (05)

- (iii) Calculate the rate constant, **k** at 227 °C.

Rate constant, $k = |\text{Rate}|$ (05)

$k = \left| \frac{(0.002 - 0.01) \text{ mol dm}^{-3}}{2000 \text{ s}} \right|$ **or** any two points (04 + 01)

$k = 4.0 \times 10^{-6} \text{ mol dm}^{-3}$ (04 + 01)

- (iv) Calculate the pressure in the container when half the initial amount of A(g) has decomposed. Assume that the volume of the catalyst can be neglected.

Volume of the container = 1.0 dm³



After 50% completion

$0.01(1-x) \quad 0.01x \quad 0.01x$ [concentrations in mol dm⁻³]

Amount of gas $t = 0$ = 0.01 mol

Amount of gas after 50% is decomposed = (0.005 + 0.005 + 0.005) mol

= 0.015 mol (05)

Assuming ideal gas behaviour, apply $PV = nRT$

$$\begin{aligned} \text{Pressure} &= \frac{0.015 \text{ mol } 8.314 \text{ JK}^{-1} \text{ mol}^{-1} 500 \text{ K}}{10^{-3} \text{ m}^3} && \text{(08 + 02)} \\ &= 6.23 \times 10^4 \text{ Pa} && \text{(04 + 01)} \end{aligned}$$

3(a) : 60 marks

- (b) In the presence of a solid catalyst, the gas **X** decomposes according to the following chemical equation.

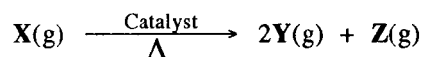

1.0 mole of gas **X** was introduced to an evacuated container. The initial volume of the gas was measured to be V_0 . The reaction was initiated by introducing a small amount of catalyst (volume is negligible). The rate constant of the catalysed reaction is k_1 and order of the reaction with respect to **X** is **b**. The initial rate of the reaction was measured as R_0 . The pressure of the system was maintained at a constant value by allowing the container to expand. The temperature of the system was also maintained at a constant value.

- (i) Write an expression for R_0 using the terms **b**, k_1 and V_0 .

Initial rate, $R_0 = k_1 [X]^b$

$$R_0 = k_1 \left(\frac{1.0 \text{ mol}}{V_0} \right)^b \text{ ——— (1)} \quad \text{(10)}$$

(Units are not required)

- (ii) It was observed that the rate of the reaction was $0.25R_0$ and the volume of the container was doubled when 50% of **X(g)** was consumed. Calculate the order **b** of the reaction.

After 50% decomposition,

$$[X] = \frac{0.5 \text{ mol}}{2V_0} \quad \text{(05)}$$

At this stage, Rate = $0.25R_0$

$$0.25R_0 = k_1 \left(\frac{0.5 \text{ mol}}{2V_0} \right)^b \text{ ——— (2)} \quad \text{(10)}$$

From (2)/(1),

$$\frac{0.25 R_0}{R_0} = \frac{k_1 \left(\frac{0.5 \text{ mol}}{2V_0} \right)^b}{k_1 \left(\frac{1.0 \text{ mol}}{V_0} \right)^b} \quad \text{(10)}$$

$$0.25 = 0.25^b$$

$$b = 1 \quad \text{(05)}$$

(Units are not required)

3(b) : 40 marks

Total for 3 : 100 marks

Overall observations, conclusions and suggestions regarding the answers to Question 3 :

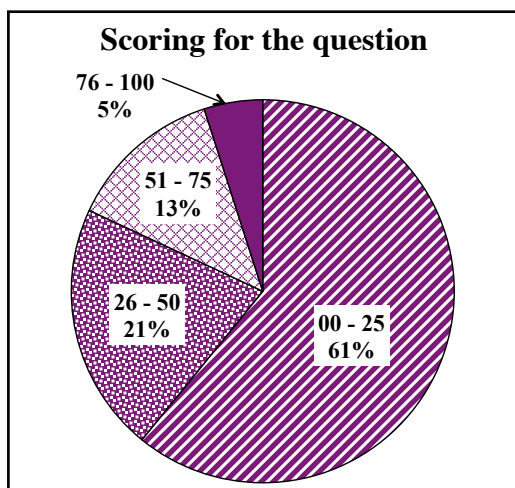

3rd question is a compulsory question and it is answered by 98%. 100 marks are allocated for this question.

Out of it : in the interval 00 - 25 61%
 in the interval 26 - 50 21%
 in the interval 51 - 75 13%
 in the interval 76 - 100 5%

5% have scored above 76 marks for this question, whereas 61% of the candidates have scored 25 marks or below.

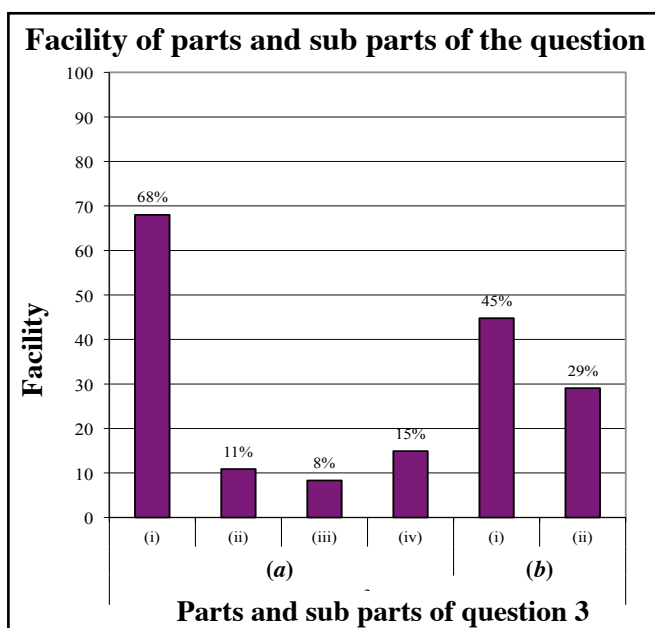

There are 6 sub parts. 5 of the sub parts is below 50% facility. Also there are four sub parts with less than 30% facility. the least facility has been shown by the part (a)(iii), which is 8%. Easiest sub part is (a)(i) and its facility is 68%. Over all facility for all the parts of this question is below 30%. (Approximately 29%) Hence, the competency level of the candidates for this question which is on chemical kinetics is not satisfactory.

68% facility for part (a) (i) shows that the ability of the candidates to write the rate equation for a given reaction is at a relatively satisfactory level. But what is expected in the problem given in (a) (ii) is to determination of the order by using the graph plotted between time and concentration. the reason for the facility to decrease upto 11% is, for not being realized that the rate becomes constant or the order becomes zero when the gradient of the graph is constant. Because, correct attention has not paid on the axes of the graph.

When the answer for part (a)(ii) is incorrect, correct answer could not be attained for part (a)(iii); hence its facility has decreased upto 8%. Other than the concepts in chemical kinetics, it is required to know about the behavior of gases and gas laws to provide answers to part (a)(iv).

The competency level of the candidates has become low due to the difficulty faced by them to find the relationship between all those concepts with each other.

Therefore it is not enough to study the concepts in Chemistry unit - wise separately, but it is very important to practice more exercises in soloing problems by applying those concepts together.

Though the facility of part (b)(i) and (ii) are somewhat greater than that of part (a), identification of the given symbols properly and substitution of them to the appropriate expressions have become a problem to the candidates.

Anyhow out of all the questions in paper II, the least facility has been shown for this question which belongs to the area of physical chemistry.

Question 4

4. (a) (i) **A, B, C** and **D** are structural isomers with the molecular formula $C_4H_{10}O$. All four isomers reacted with metallic sodium to evolve H_2 gas. Of the four isomers, only **A** exhibited optical isomerism. When **B, C** and **D** were added separately to conc. HCl , containing $ZnCl_2$, the mixture containing **B** became turbid very rapidly. The development of turbidity with **C** and **D** was very slow. When **C** and **D** were heated with conc. H_2SO_4 , **E** and **F** were respectively obtained. **E** and **F** are structural isomers with the molecular formula C_4H_8 . Neither **E** nor **F** exhibited geometric isomerism. When **E** and **F** were treated with HBr , **G** and **H** were respectively obtained. Only **G** exhibited optical isomerism. Draw the structures of **A, B, C, D, E, F, G** and **H** in the boxes given below. (It is **not necessary** to draw stereoisomeric forms.)

$CH_3CH_2\underset{\substack{ \\ OH}}{CH}-CH_3$	$CH_3-\overset{\substack{OH \\ }}{C}-\underset{\substack{ \\ OH}}{CH_3}$	$CH_3CH_2CH_2CH_2OH$
A	B	C
$CH_3-\overset{\substack{CH_3 \\ }}{C}-\underset{\substack{ \\ H}}{CH_2}OH$	$CH_3CH_2CH=CH_2$	$CH_3-\overset{\substack{CH_3 \\ }}{C}=CH_2$
D	E	F
$CH_3CH_2\underset{\substack{ \\ Br}}{CH}-CH_3$	$CH_3-\overset{\substack{CH_3 \\ }}{C}-\underset{\substack{ \\ Br}}{CH_3}$	Note : If A is incorrect, no marks for I. If C is incorrect, no marks for J.
G	H	

(05 × 8 = 40 marks)

- (ii) When **A** and **C** were reacted with PCC, **I** and **J** were respectively obtained. Draw the structures of **I** and **J** in the boxes given below. (PCC = Pyridinium chlorochromate)

$C_2H_5-\overset{\substack{O \\ }}{C}-CH_3$	$CH_3CH_2CH_2-\overset{\substack{O \\ }}{C}-H$
I	J

(05 × 2 = 10 marks)

4(a) : 50 marks

- (b) Draw the structure of the **major** organic products **K, L, M, N, O, P, Q, R, S** and **T** of the following reactions in the relevant boxes given on page 8.

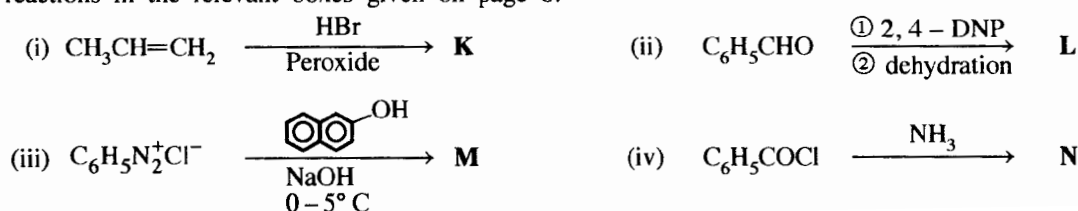

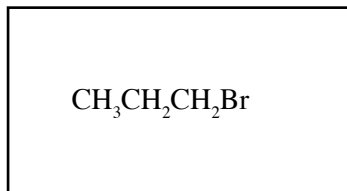
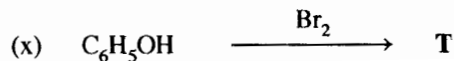
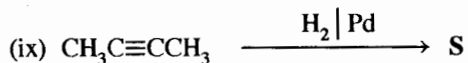
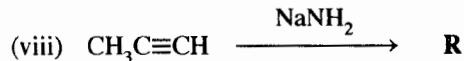
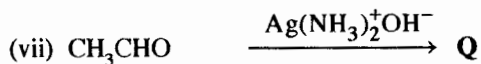
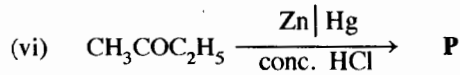
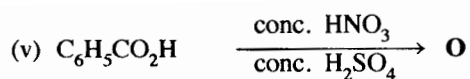

K

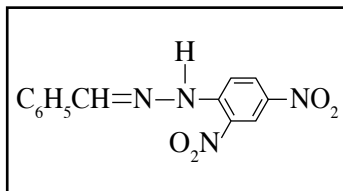

L

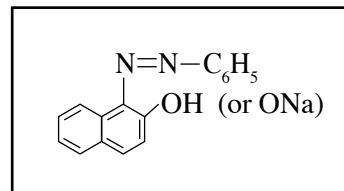

M

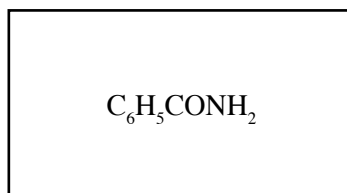

N

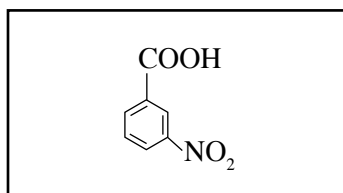

O

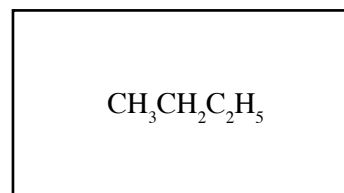

P

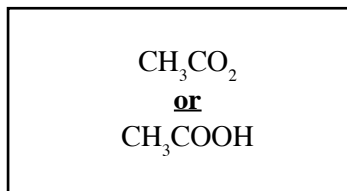

Q

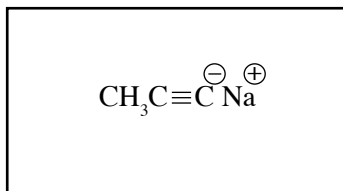

R

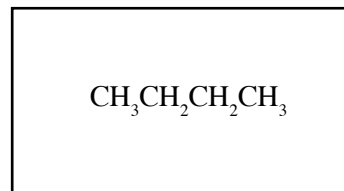

S

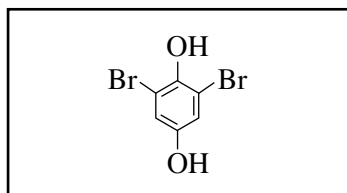

T

Note : **Q** : Disregard cation

R : Do not award marks for the following structures

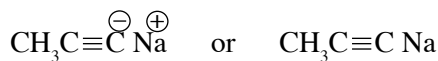

(03 × 10 = 30 marks)

4(b) : 30 marks

(c) Write the mechanism for the reaction between $C_2H_5CH=CHC_2H_5$ and $Br_2(CCl_4)$.

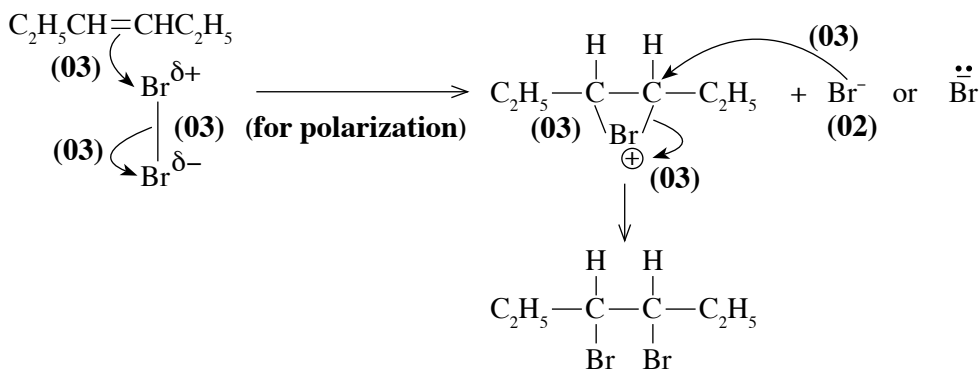

Nate : If cyclic intermediate is not drawn, do not award 06 marks

4(c) : 20 marks

Total for 4 : 100 marks

Overall observations, conclusions and suggestions regarding the answers to Question 4 :

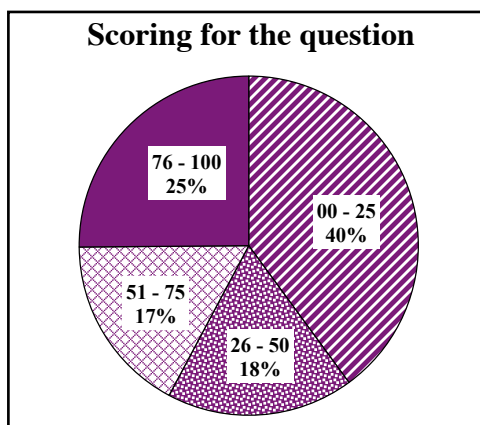

Though this fourth question is compulsory, it is answered by 98%. 100 marks are allocated for this question

Out of it : in the interval; 00 - 25 40%
 in the interval 26 - 50 18%
 in the interval 51 - 75 17%
 in the interval 76 - 100 25%
have scored marks.

For this question 25 % have scored above 76 marks whereas 40 % of the candidates have scored 25 marks or below.

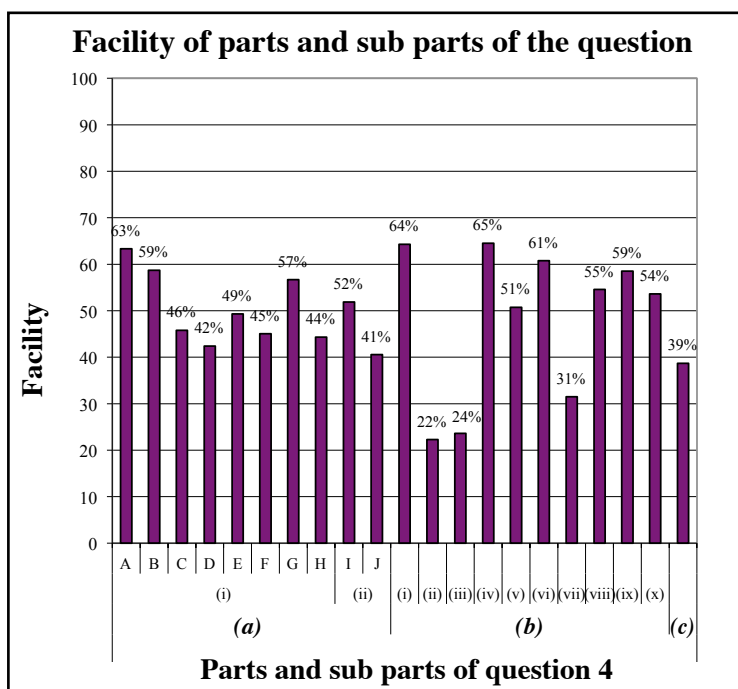

This question comprises 21 sub parts. Out of them there are ten parts with the facility 50% or less than that. The least facility has been shown by the sub part (b)(ii) and its facility is 22%. Easiest sub parts are (b)(i) and (b)(iv) and their facility is 64.5%.

Overall facility of this question is 48 % and out of all the questions in paper II, highest facility has been shown for this question which belongs to organic chemistry. Out of the 10 parts from A to J in part (a) 4 parts have been shown above 50 % facility. These questions are set from the basic concepts in organic chemistry and those are familiar questions to the candidates.

Questions asked in all the parts in(b) is to write down the products when reactants and reagents are given. Parts (b)(ii) and (b)(iii) have been shown least facility 22% and 24% respectively. A reason for low facility in (b)(ii) is unawareness of the formula of the reagent when it is given only in the name as 2,4 DNP instead of giving the structure. Though the reagent of the part (iii) has been given the structure of the product forms is fairly large and complex it has become bit difficult to be memorized.

Though the part (c) is a familiar question on the mechanisms of reactions, its facility being 39% in this year too, seems that the students have poor sense on it. To get rid of this problem it is important to practice and guide them practice the same mechanism several times.

Question 5

5. (a) The procedure given below was followed to determine the partition coefficient, K_D of butanedioic acid (BDA, $\text{HOOCCH}_2\text{CH}_2\text{COOH}$) between ether and water at 25 °C.

Initially, 20 g of solid BDA was shaken well with a mixture of approximate volumes of 100 cm³ of ether and 100 cm³ of water in a reagent bottle and the layers were allowed to separate. At this stage, some undissolved BDA was seen remaining at the bottom of the reagent bottle. Thereafter, a 50.00 cm³ volume of ether layer and a 25.00 cm³ volume of water layer were titrated with 0.05 mol dm⁻³ NaOH solution. The volumes taken from the ether and water layers required 4.80 cm³ and 16.00 cm³ of the NaOH solution respectively.

- Calculate the partition coefficient, K_D for the distribution of butanedioic acid between ether and water at 25 °C.
 - Calculate the solubility of butanedioic acid in ether, given that the solubility of this acid in water is 8.0 g dm⁻³.
- (b) Consider the following reactions. Thermodynamic data supplied are **not** for the standard state.

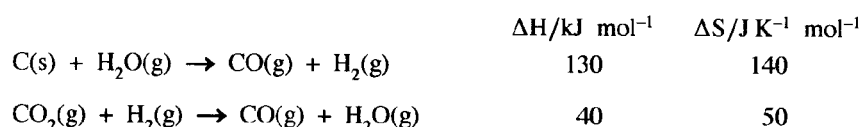

- Calculate ΔH and ΔS for the reaction $2\text{CO(g)} \rightarrow \text{C(s)} + \text{CO}_2\text{(g)}$. State giving reasons whether the sign of ΔS agrees with the reaction taking place.
 - By means of a suitable calculation, predict whether the reaction given in part (i) above is spontaneous at 27 °C.
- (c) An excess amount of C(s) and 0.15 mol of CO₂(g) were placed in a closed rigid 2.0 dm³ container and the system was allowed to reach equilibrium at a temperature of 689 °C. Once the equilibrium was achieved, the pressure in the container was found to be 8.0×10^5 Pa. (Take $RT = 8000 \text{ J mol}^{-1}$ at 689 °C)
- Write an expression for the equilibrium constant, K_p for the reaction $\text{C(s)} + \text{CO}_2\text{(g)} \rightleftharpoons 2\text{CO(g)}$.
 - Calculate K_p and K_c at 689 °C.
 - In another experiment, the container described above contains an excess of C(s) together with CO(g) and CO₂(g) at 689 °C. The initial partial pressure of each gas is 2.0×10^5 Pa. Explain, with the aid of a calculation, the change in partial pressure of CO₂(g) when the system reaches equilibrium.

5. (a) (i) $\frac{n_{\text{butanedioic acid}}}{n_{\text{NaOH}}} = \frac{1}{2}$ **or** for the identification of stoichiometry (05)

Butanedioic acid = BDA

Ether layer

$$C_{\text{BDA}_{\text{ether}}} = \frac{1}{2} \times 0.05 \text{ mol dm}^{-3} \times 4.8 \text{ cm}^3 / 50.00 \text{ cm}^3 \quad (03)$$

$$= 2.4 \times 10^{-3} \text{ mol dm}^{-3} \quad (04 + 01)$$

Aqueous layer

$$C_{\text{BDA}_{\text{aq}}} = \frac{1}{2} \times 0.05 \text{ mol dm}^{-3} \times 16.0 \text{ cm}^3 / 25.00 \text{ cm}^3 \quad (02)$$

$$= 1.6 \times 10^{-2} \text{ mol dm}^{-3} \quad (04 + 01)$$

$$K_D = \frac{[\text{BDA}]_{\text{ether}}}{[\text{BDA}]_{\text{aqueous}}} \quad (05)$$

$$= \frac{2.4 \times 10^{-3} \text{ mol dm}^{-3}}{1.6 \times 10^{-2} \text{ mol dm}^{-3}} = 0.15 \text{ **or** } 3/20 \quad (04 + 01)$$

or $K_D = \frac{[\text{BDA}]_{\text{aqueous}}}{[\text{BDA}]_{\text{ether}}}$

$$= \frac{1.6 \times 10^{-2} \text{ mol dm}^{-3}}{2.4 \times 10^{-3} \text{ mol dm}^{-3}} = 6.67 \text{ **or** } 20/3$$

Note : Steps can be combined, award marks accordingly.

(ii) Solubility

$$[BDA]_{\text{ether}} = K_D [BDA]_{\text{Water}} \quad (03)$$

$$= 2.4 \times 10^{-3} \text{ mol dm}^{-3} \quad (04 + 01)$$

Consider a mixture having 1.0 dm³ of ether layer and 1.0 dm³ of aqueous layer.

$$\frac{x}{M_{\text{BDA}}} = \frac{0.15(8.0 \text{ g dm}^{-3})}{M_{\text{BDA}}} \quad (05)$$

$$x = 1.2 \text{ g dm}^{-3} \quad (04 + 01)$$

Note : Equation can be accepted without M_{BDA} .

5(a) : 40 marks

(b) (i) Write the two reactions as follows and add.

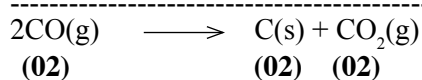
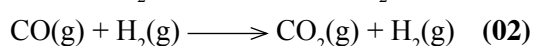
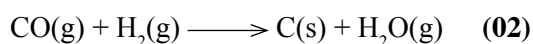

(Overall reaction must be generated by adding the two reactions for awarding marks)

(Physical states are required)

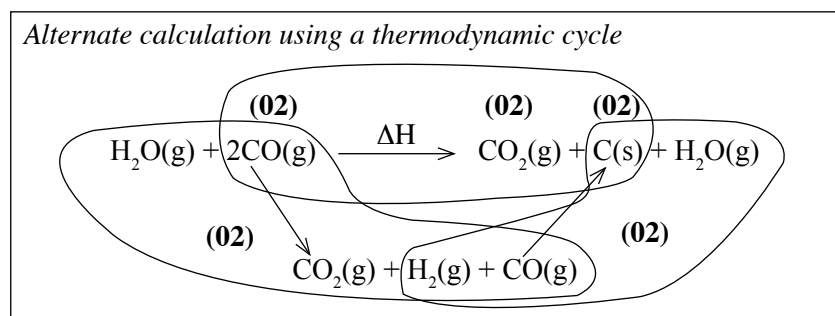

$$\Delta H = -130 \text{ kJ mol}^{-1} - 40 \text{ kJ mol}^{-1} = -170 \text{ kJ mol}^{-1} \quad (04 + 01)$$

$$\Delta S = -140 \text{ JK}^{-1} \text{ mol}^{-1} - 50 \text{ JK}^{-1} \text{ mol}^{-1} = -190 \text{ JK}^{-1} \text{ mol}^{-1} \quad (04 + 01)$$

(If standard states are written, do not award marks)

Sign of ΔS is negative. This agrees with the reduction of entropy, mainly due to the reduction of the number of moles of gases as the forward reaction progresses. (05)

(ii) Find ΔG at 27°C.

$$\Delta G = \Delta H - T\Delta S \quad (02)$$

(If standard states are written, do not award marks)

$$\Delta G = -170 \text{ kJ mol}^{-1} - 300 \text{ K}^{-1} \text{ mol}^{-1} \times (-190 \times 10^{-3} \text{ kJ K}^{-1} \text{ mol}^{-1}) \quad (04 + 01)$$

$$\Delta G = -113 \text{ kJ mol}^{-1} \quad (04 + 01)$$

Forward reaction is spontaneous. (03)

(Calculation must be shown for last 03 marks)

5(b) : 40 marks

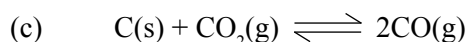

(i) $K_p = \frac{P_{CO}^2}{P_{CO_2}}$ (05)

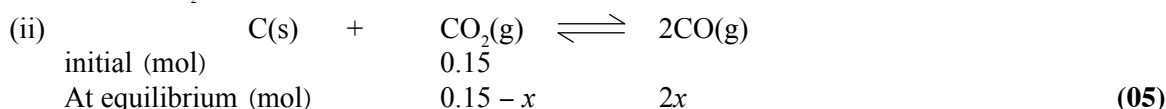

Total number of gas moles = 0.15 - x (04 + 01)

Apply PV = nRT assuming ideal behaviour.

$$0.15 + x = \frac{8.0 \times 10^5 \text{ Pa} \cdot 2.0 \times 10^{-3} \text{ m}^3}{8.0 \times 10^5 \text{ J mol}^{-2}} \quad (04 + 01)$$

$$x = 0.05 \text{ mol} \quad (04 + 01)$$

$n_{CO} = 0.1 \text{ mol}$ $n_{CO_2} = (0.15 - 0.05) \text{ mol} = 0.10 \text{ mol}$

(03) (02)

Therefore,

$P_{CO} = 2 \times 0.05 \times 8.0 \times 10^5 \text{ Pa} / 0.2 = 4.0 \times 10^5 \text{ Pa}$ (04 + 01)

$P_{CO_2} = 0.1 \times 8.0 \times 10^5 \text{ Pa} / 0.2 = 4.0 \times 10^5 \text{ Pa}$ (04 + 01)

$K_p = \frac{(4.0 \times 10^5 \text{ Pa})^2}{4.0 \times 10^5 \text{ Pa}}$ (04 + 01)

$= 4.0 \times 10^5 \text{ Pa}$ (04 + 01)

Alternate calculation

$n_{\text{total}} = 0.20 \text{ mol}, \therefore X_{CO} = X_{CO_2} = 1/2$ (05)

$P_{CO} = 8 \times 10^3 \times 1/2 = 4 \times 10^3 \text{ Pa}$ (04 + 01)

$P_{CO_2} = 8 \times 10^3 \times 1/2 = 4 \times 10^3 \text{ Pa}$ (04 + 01)

$K_p = (4 \times 10^3 \text{ Pa})^2 / 4 \times 10^3 \text{ Pa}$ (04 + 01)

$K_p = 4 \times 10^3 \text{ Pa}$ (04 + 01)

$K_c = K_p(RT)^{-\Delta n}$ **or** $K_p = K_c(RT)^{-\Delta n}$ (03)

$\Delta n = 1$ (02)

$K_c = 4.0 \times 10^5 \text{ Pa} \times (8 \times 10^3 \text{ J mol}^{-1})^{-1}$

$K_c = 50 \text{ mol m}^{-3}$ **or** 0.05 mol dm^{-3} (04 + 01)

Alternate calculation

$K_c = [CO]^2 / [CO_2]$ (05)

$= [0.10 / (2 \times 10^{-3})]^2 / [0.10 / (2 \times 10^{-3})]$

$= 50 \text{ mol m}^{-3} (0.05 \text{ mol dm}^{-3})$ (04 + 01)

(iii) Calculate Q using the pressures.

$Q = \frac{(2.0 \times 10^5 \text{ Pa})^2}{2.0 \times 10^5 \text{ Pa}} = 2.0 \times 10^5 \text{ Pa}$ (05)

Q is smaller than K_p . Therefore, P_{CO_2} decreases and P_{CO} increases until $Q = K_p$. (05)

Alternate calculation

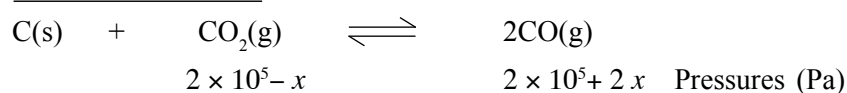

$K_p = 4.0 \times 10^5 = \frac{(2 \times 10^5 + 2x)^2}{2.0 \times 10^5 - x}$ (05)

Solving the quadratic equation and predicting the P_{CO_2} decreases and P_{CO} increases. (05)

5(c) : 70 marks

Total for 5 : 150 marks

Overall observations, conclusions and suggestions regarding the answers to Question 5 :

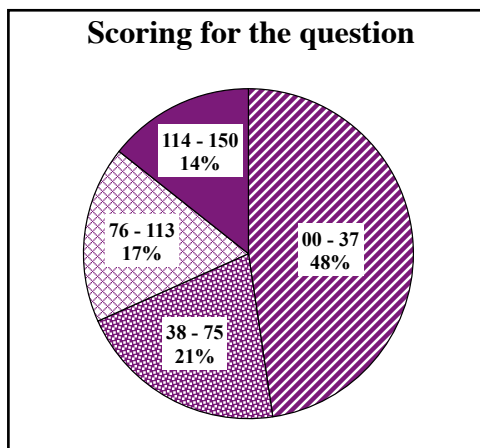

This question has been selected by 71% approximately. Out of the two physical chemistry question in part B, this is the question selected by the majority. 150 marks are allocated for this question.

Out of it : in the interval 00 – 37 48 %
 in the interval 38 – 75 21 %
 in the interval 76 – 113 17 %
 in the interval 114 – 150 14 %
 have scored marks.

For this question 14 % have scored 114 marks or above whereas 48 % of the candidates have scored 37 marks or below.

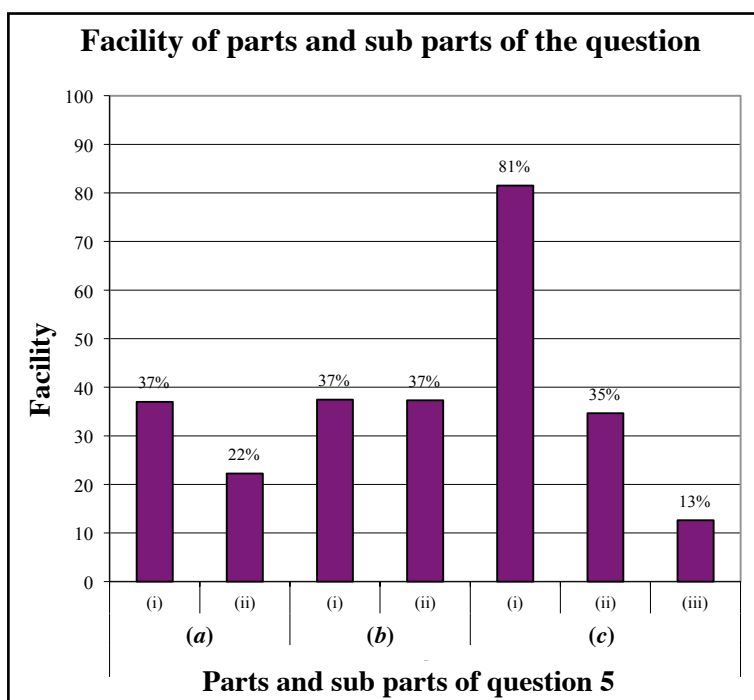

This question comprises 7 sub parts. Out of them there are two parts with the facility 25% or less than that. The least facility has been shown by the sub part (c)(iii) and its facility is 13%. Easiest sub part is (c)(i) and its facility is 81%.

This is the question selected by highest number of candidates out of all the questions in part B of the paper II and its overall facility is 36 % . But except in part (c)(i) facility of all the other six parts are less than 40%. It is obvious that even the facility of part (c)(i) has become 81% as it is asked only to write the K_p expression for a given reaction.

5(a) is a question has been set related to the homogeneous phase equilibria. Though the question is related to the basic concepts in the diffusion of a substance between two immiscible solvents, the answers provided are at a low level. The reason is enough attention may not have paid for this fact as it is included in the latter part of the syllabus. Both the parts in 5(b) show the same facility (37%). This part is very simple which is based on the basic concepts in thermodynamics. Though by the addition of the given two equations the required equation could be obtained, clearly seen that it has been neglected.

It should be specially emphasized in the teaching – learning process that it is sufficient to practice the basic concepts given in the syllabus to solve problems other than solving very complicated problems.

Least facility (13 %) has been shown in part 5(c). The reason for very low facility is, though the question is simple it has not been understood correctly.

Question 6

6. (a) A 0.10 mol dm^{-3} solution of a weak acid, **HA** was prepared by diluting an appropriate amount of the pure weak acid to 25.00 cm^3 with distilled water in a volumetric flask at $25 \text{ }^\circ\text{C}$. The pH of this solution was 3.0.
- Considering the equation, $\text{HA}(\text{aq}) + \text{H}_2\text{O}(\text{l}) \rightleftharpoons \text{H}_3\text{O}^+(\text{aq}) + \text{A}^-(\text{aq})$, calculate the dissociation constant, K_a of the weak acid.
 - A dilute solution of this weak acid, **HA** was titrated with a strong base, **BOH**. It was found that the pH of the titration mixture after reaching the equivalence point was 9.0. Calculate the concentration of the salt, **AB** in the titration mixture. ($K_w = 1.0 \times 10^{-14} \text{ mol}^2 \text{ dm}^{-6}$ at $25 \text{ }^\circ\text{C}$)
 - The above titration mixture was diluted hundred times by adding distilled water. Calculate the pH of the diluted titration mixture.
- (b) $\text{AgBr}(\text{s})$ is a pale-yellow coloured salt sparingly soluble in water. Its solubility product, K_{sp} is $5.0 \times 10^{-13} \text{ mol}^2 \text{ dm}^{-6}$ at $25 \text{ }^\circ\text{C}$.
- Calculate the concentration of $\text{Ag}^+(\text{aq})$ in a saturated solution of AgBr in equilibrium with solid AgBr at $25 \text{ }^\circ\text{C}$.
 - Solid AgBr together with 100.0 cm^3 of the solution described in part (i) above were placed in a beaker. A volume of 100.0 cm^3 of distilled water was added to the beaker and the mixture was stirred well until the equilibrium is reached. At this stage, some solid AgBr was still left at the bottom of the beaker. What could be the concentration of $\text{Ag}^+(\text{aq})$ in this solution? Explain your answer.
 - Using a suitable calculation, predict the observation expected when 10.0 cm^3 of a $1.5 \times 10^{-4} \text{ mol dm}^{-3}$ AgNO_3 solution and 5.0 cm^3 of a $6.0 \times 10^{-4} \text{ mol dm}^{-3}$ NaBr solution are mixed at $25 \text{ }^\circ\text{C}$.
- (c) (i) The pressure of the vapour phase in equilibrium with an ideal binary solution is P . The liquid phase mole fractions of the two components are X_1 and X_2 , and their respective saturated vapour pressures are P_1^0 and P_2^0 . Show that
- $$X_1 = \frac{P - P_2^0}{P_1^0 - P_2^0}.$$
- The pressure of the vapour phase in equilibrium with a binary solution containing methanol and ethanol is $4.5 \times 10^4 \text{ Pa}$ at $50 \text{ }^\circ\text{C}$. At this temperature the saturated vapour pressures of methanol and ethanol are $5.5 \times 10^4 \text{ Pa}$ and $3.0 \times 10^4 \text{ Pa}$ respectively. Consider that the solutions behave ideally.
 - Calculate the mole fractions of methanol and ethanol in the liquid phase.
 - Calculate the mole fractions of methanol and ethanol in the vapour phase.
 - Based on the above calculations and given information, draw the vapour pressure - composition diagram of the methanol - ethanol mixture at $50 \text{ }^\circ\text{C}$. Consider that the solutions behave ideally.

6. (a) (i) $\text{pH} = 3.0$

$$[\text{H}^+] = 1.0 \times 10^{-3} \text{ mol dm}^{-3} \quad (04 + 01)$$

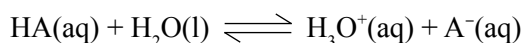

$$K_a = \frac{[\text{H}_3\text{O}^+(\text{aq})][\text{A}^-(\text{aq})]}{[\text{HA}(\text{aq})]} \quad (02)$$

(Physical states are required)

$$= \frac{(1.0 \times 10^{-3} \text{ mol dm}^{-3})^2}{0.10 \text{ mol dm}^{-3}} \quad (02 + 01)$$

$$= 1.0 \times 10^{-5} \text{ mol dm}^{-3} \quad (02 + 01)$$

(ii) pH at the equivalence point is determined by the degree of hydrolysis of the salt.

Consider,



$$\frac{K_a}{K_w} = \frac{[H_3O^+(aq)][A^-(aq)]}{[HA(aq)][OH^-(aq)]}$$

At the equivalence point $[HA(aq)] \approx [OH^-(aq)]$

$$\frac{K_a}{K_w} = \frac{[A^-(aq)]}{[OH^-(aq)]^2}$$

$$[OH^-(aq)] = \left[[A^-(aq)] \frac{K_w}{K_a} \right]^{1/2} \quad (1) \quad (05)$$

At the equivalence point $[A^-(aq)] = [\text{salt}]$

Since pH = 9.0 at the equivalence point, $[OH^-] = 10^{-5} \text{ mol dm}^{-3}$ (02)

$$[\text{salt}] = ([OH^-(aq)])^2 \frac{K_a}{K_w}$$

$$[\text{salt}] = (1.0 \times 10^{-5} \text{ mol dm}^{-3})^2 \frac{1.0 \times 10^{-5} \text{ mol dm}^{-3}}{1.0 \times 10^{-14} \text{ mol}^2 \text{ dm}^{-6}} \quad (04 + 01)$$

$$= 0.1 \text{ mol dm}^{-3} \quad (04 + 01)$$

(iii) When the titration mixture at the equivalence point is 100 times diluted,

(The salt concentration is decreased by 100 times)

Using the equation - (1)

$$[OH^-(aq)]_{\text{new}} = \left[\frac{[A^-(aq)]}{100} \frac{K_w}{K_a} \right]^{1/2} \quad (05)$$

$$[OH^-(aq)]_{\text{new}} = \frac{1}{10} \left[\frac{[A^-(aq)]}{1} \frac{K_w}{K_a} \right]^{1/2}$$

$$[OH^-(aq)]_{\text{new}} = \frac{1}{10} \left[\frac{[0.1 \text{ mol dm}^{-3}]}{1} \frac{1 \times 10^{-14} \text{ mol}^2 \text{ dm}^{-6}}{1 \times 10^{-5} \text{ mol dm}^{-3}} \right]^{1/2} \quad (04 + 01)$$

$$[OH^-(aq)] = 1.0 \times 10^{-6} \text{ mol dm}^{-3}$$

$$[H_3O^+(aq)] = 1.0 \times 10^{-8} \text{ mol dm}^{-3}$$

Therefore, pH = 8.0 (05)

Alternate calculation

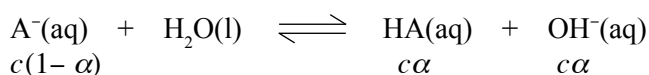

By Ostwalds law,

$$K_b = \alpha^2 c = \frac{\alpha^2 c^2}{c} = \frac{[OH^-]^2}{c}$$

$$[OH^-] = \sqrt{K_b c} = \sqrt{\frac{K_a}{K_w} c} \qquad \qquad \qquad (05)$$

$$[\text{salt}] = [A^-] = c = 0.1 \text{ mol dm}^{-3}/100$$

$$[OH^-] = \sqrt{\frac{1 \times 10^{-14} \text{ mol}^2 \text{ dm}^{-6}}{1 \times 10^{-5} \text{ mol dm}^{-3}} \times \frac{1 \times 10^{-1} \text{ mol dm}^{-3}}{100}} = 1 \times 10^{-6} \text{ mol dm}^{-3} \qquad (04 + 01)$$

$$\text{pOH} = 6.0$$

$$\text{pH} = 8.0 \qquad \qquad \qquad (05)$$

6(a) : 50 marks



$$K_{SP} = [\text{Ag}^+(aq)][\text{Br}^-(aq)] \qquad \qquad \qquad (03)$$

$$[\text{Ag}^+(aq)] = [\text{Br}^-(aq)] = x$$

$$K_{SP} = x^2 \qquad \qquad \qquad (02)$$

$$\text{Therefore, } [\text{Ag}^+(aq)] = (5.0 \times 10^{-13})^{1/2}$$

$$= 7.07 \times 10^{-7} \text{ mol dm}^{-3} \quad \text{or} \quad 7.1 \times 10^{-7} \text{ mol dm}^{-3} \qquad \qquad \qquad (04 + 01)$$

(ii) The solution is a saturated solution of AgBr. (05)

$$\text{Therefore, } [\text{Ag}^+(aq)] \text{ is as same as above, } 7.07 \times 10^{-7} \text{ mol dm}^{-3} \qquad \qquad \qquad (05)$$

(iii) The product of concentrations of Ag^+ and Br^- must be calculated and compared with K_{SP} .

$$\begin{aligned} [\text{Ag}^+(aq)] &= 1.5 \times 10^{-4} \text{ mol dm}^{-3} \times 10.00 \text{ cm}^3 / 15.00 \text{ cm}^3 \\ &= 1.0 \times 10^{-4} \text{ mol dm}^{-3} \qquad \qquad \qquad (04 + 01) \end{aligned}$$

$$\begin{aligned} [\text{Br}^-(aq)] &= 6.0 \times 10^{-4} \text{ mol dm}^{-3} \times 5.00 \text{ cm}^3 / 15.00 \text{ cm}^3 \\ &= 2.0 \times 10^{-4} \text{ mol dm}^{-3} \qquad \qquad \qquad (04 + 01) \end{aligned}$$

$$[\text{Ag}^+(aq)] \times [\text{Br}^-(aq)] = 2.0 \times 10^{-8} \text{ mol}^2 \text{ dm}^{-6} > K_{SP} \qquad \qquad \qquad (10)$$

[or any other correct approach]

Therefore, AgBr will precipitate (slightly yellow oreprecitate will form) (05)

6(b) : 50 marks

(c) (i) Applying Raoult's law to the ideal binary mixture,

$$P_i = x_i P_i^0 \quad (05)$$

$$P = P_1 + P_2 \quad (05)$$

$$P = x_1 P_1^0 + x_2 P_2^0 \quad (05)$$

$$x_2 = 1 - x_1$$

$$P = x_1 P_1^0 + (1 - x_1) P_2^0$$

$$x_1 = \frac{(P - P_2^0)}{(P_1^0 - P_2^0)} \quad (05)$$

(ii) I Mole fractions in the liquid phase,

$$x_{\text{meOH}} = (4.5 - 3.0)10^4 \text{ Pa} / (5.5 - 3.0)10^4 \text{ Pa} = 0.6 \quad (04 + 01)$$

$$x_{\text{etOH}} = 1 - 0.6 = 0.4 \quad (04 + 01)$$

II Mole fractions in the gas phase,

$$x_{\text{methanol_gas}} = 0.6 \times 5.5 \times 10^4 \text{ Pa} / 4.5 \times 10^4 \text{ Pa} = 0.73 \quad (04 + 01)$$

$$x_{\text{ethanol_gas}} = 1.0 - 0.73 = 0.27 \quad (04 + 01)$$

(Answers can be given as fractions)

(iii) Pressure composition diagram (ideal mixture)

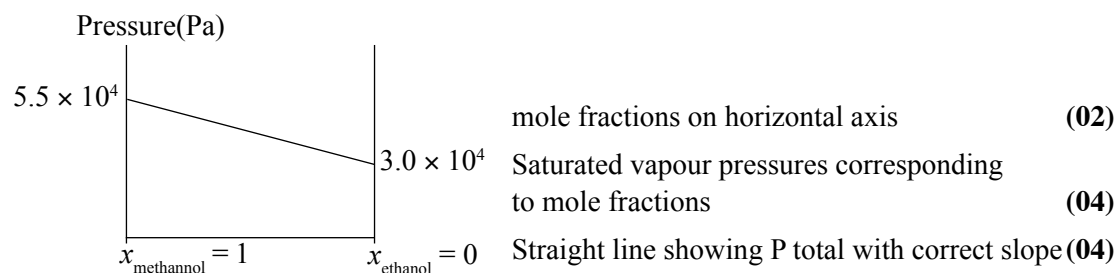

Note : If more than one line is drawn, P total line must be labeled.

6(c) : 50 marks

Total for 6 : 150 marks

Overall observations, conclusions and suggestions regarding the answers to Question 6 :

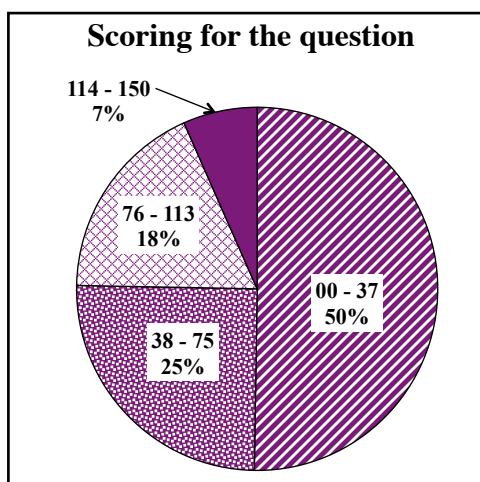

Question 6 has been selected by 58% approximately. 150 marks are allocated for this question.

Out of it : in the interval 00 – 37 50%
 in the interval 38 – 75 25%
 in the interval 76 – 113 18%
 in the interval 114 – 150 07%

have scored marks.

For this question 7% have scored 114 marks or above whereas 50% of the candidates have scored 37 marks or below.

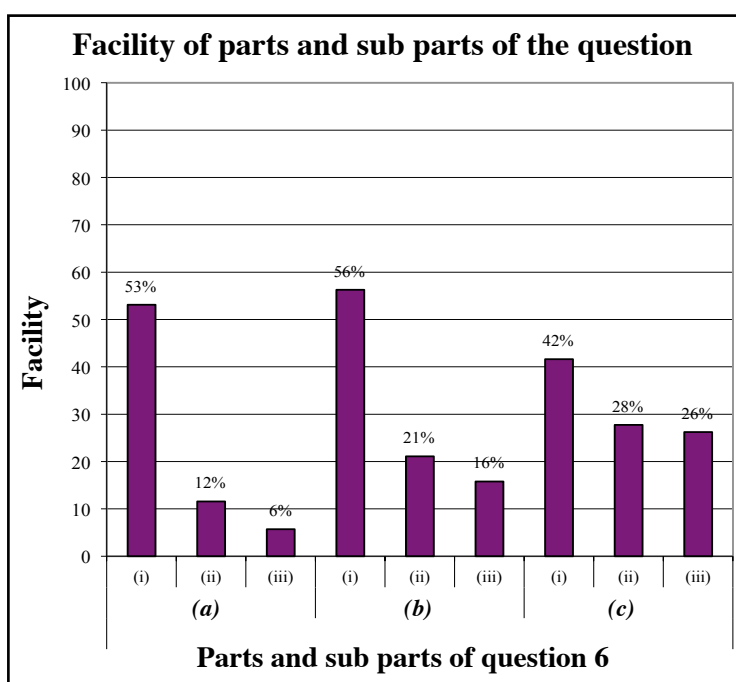

This question comprises 9 sub parts. Out of them there are six parts with the facility 35% or less than that. The least facility has been shown by the sub part (a)(iii) and its facility is 6%. Easiest sub part is (b)(i) and its facility is 56%.

Question can be considered as with overall low facility. Containing less theoretical parts in the and not practicing the calculations can be given as the reasons for it.

It should be reminded again the requirement of practicing the capability of analyzing the problems. Though part (c)(iii) is easy, has been unable to score its marks for not giving the correct answers to the previous parts.

It is important to pay more attention on the subject matter regarding the salt hydrolysis and phase equilibrium.

Question 7

7. (a) Using **only** the chemicals given in the list, show how you would carry out the following conversion.

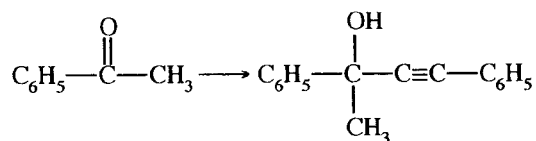

List of chemicals

H_2O , alcoholic KOH , Br_2 , Conc. H_2SO_4 ,
 NaBH_4 , $\text{C}_2\text{H}_5\text{MgBr}$ /dry ether

Your conversion should not exceed 9 steps.

(b) Identify $\text{R}_1 - \text{R}_6$ and $\text{X}_1 - \text{X}_5$ in order to complete the following reaction scheme.

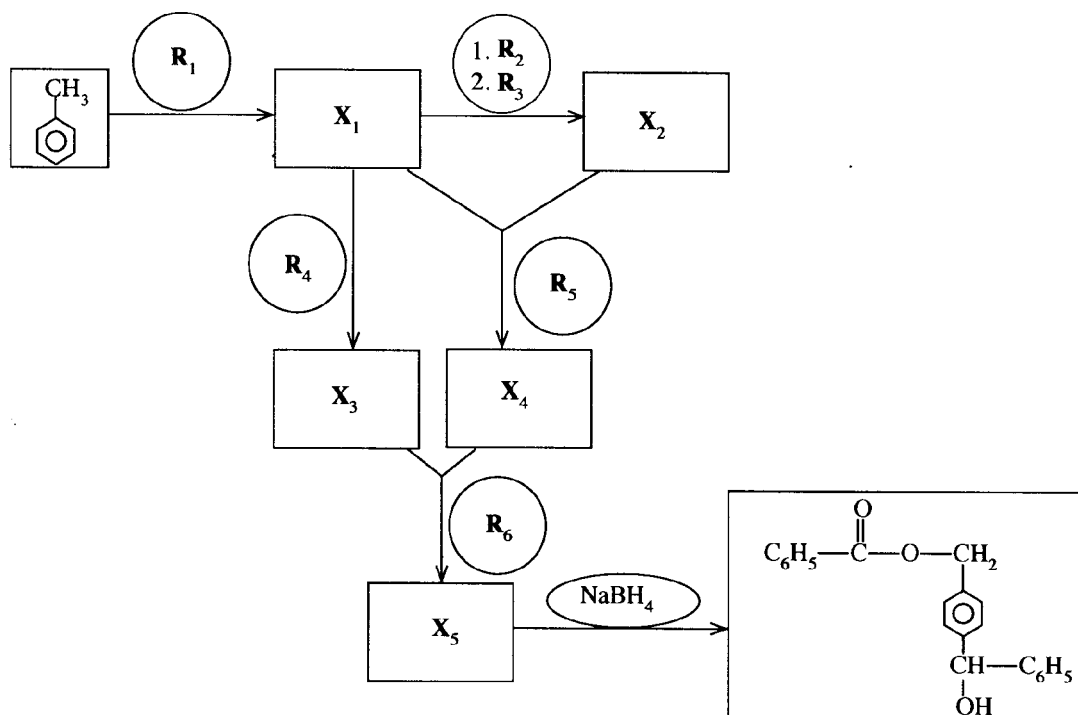

(c) (i) Give the mechanism for the following reaction.

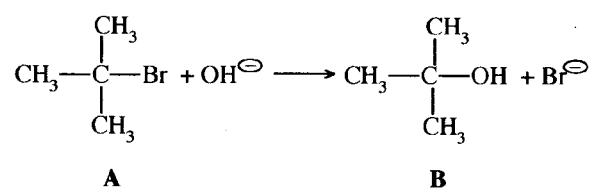

(ii) The reaction of **A** with NaOH , gives in addition to **B** another product **C**. Give the structure of **C**.

7. (a)

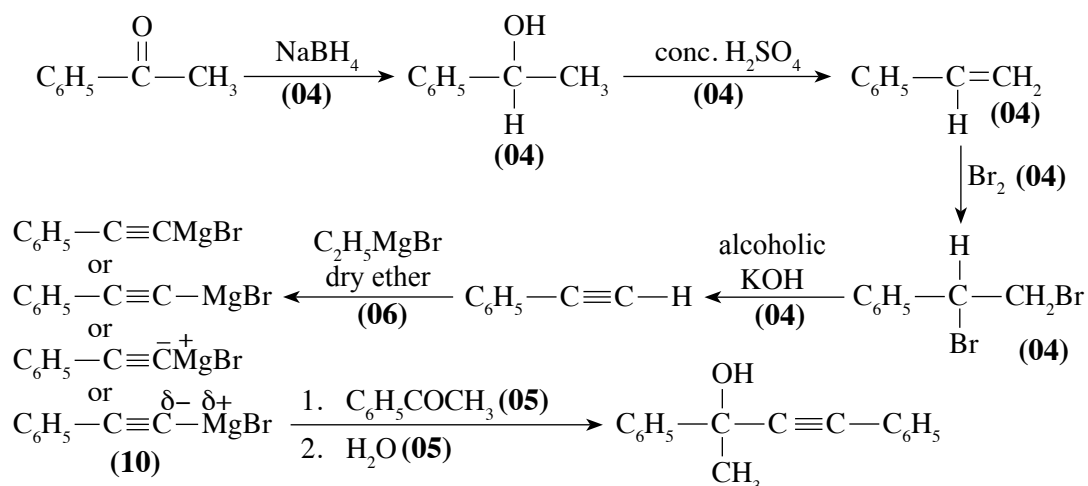

Note : Disregard reaction medium of NaBH₄.

Alternate step

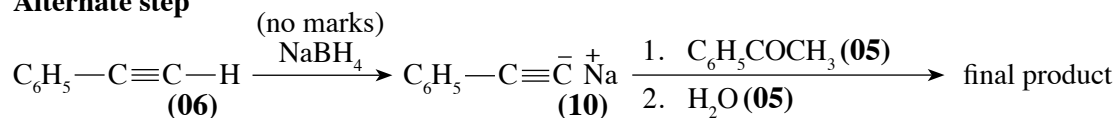

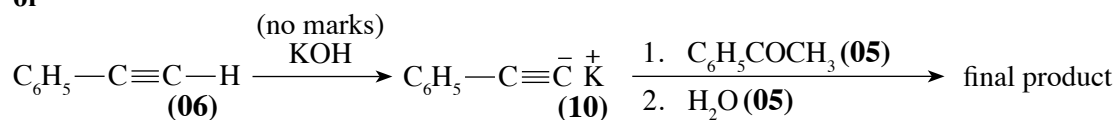

or

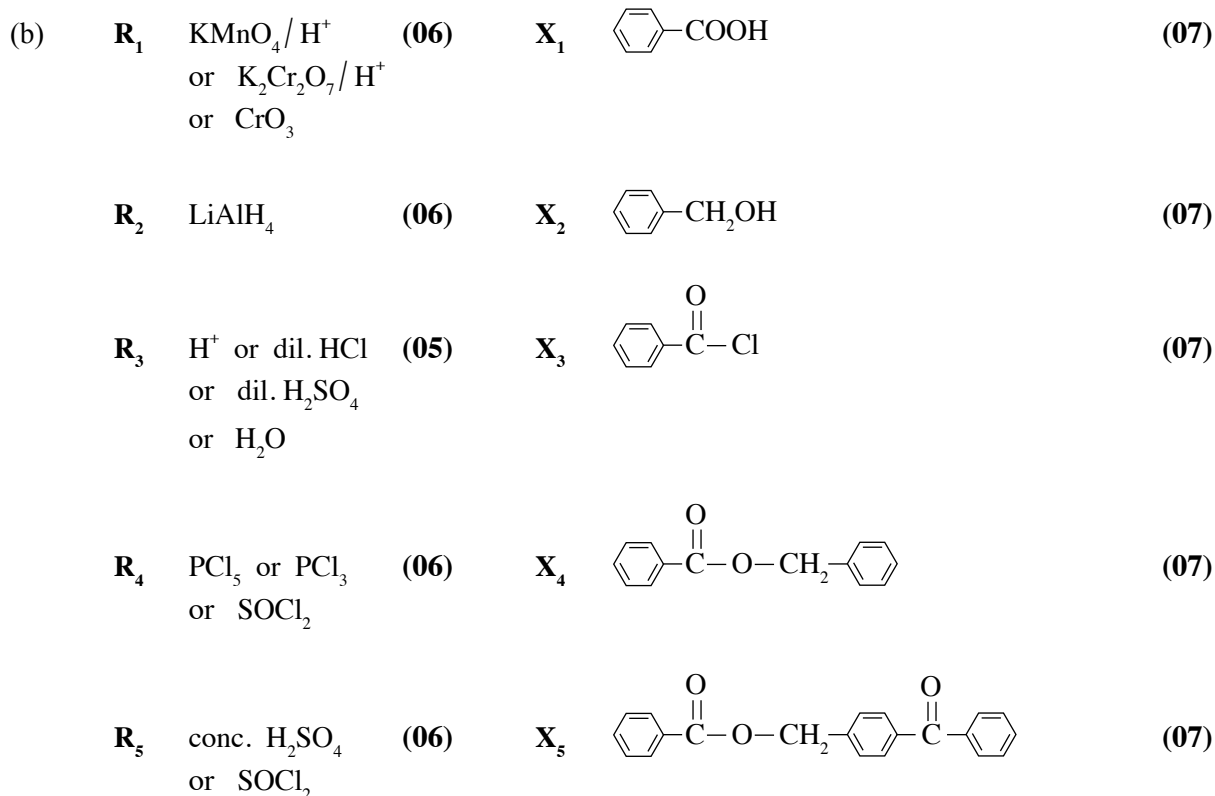

7(a) : 60 marks

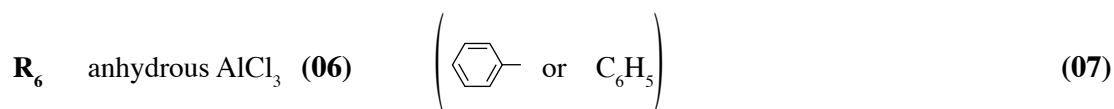



Note : For X₁ to X₄, if  is given instead of  penalize only once.
For X₅, all aromatic rings must be shown for award of marks.

7(b) : 70 marks

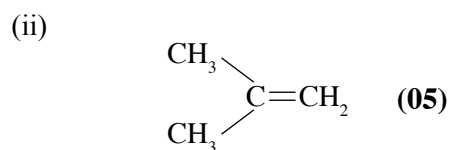
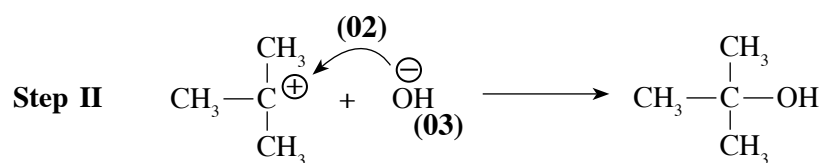
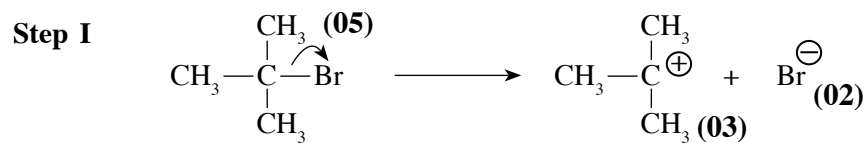
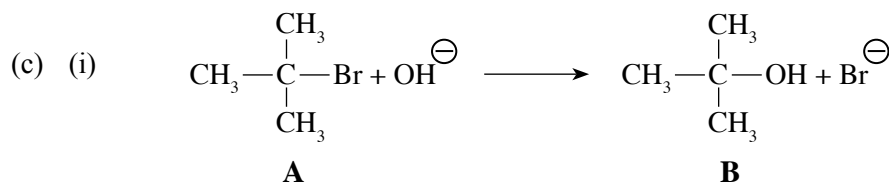

7(c) : 20 marks

Total for 7 : 150 marks

Overall observations, conclusions and suggestions regarding the answers to Question 7 :

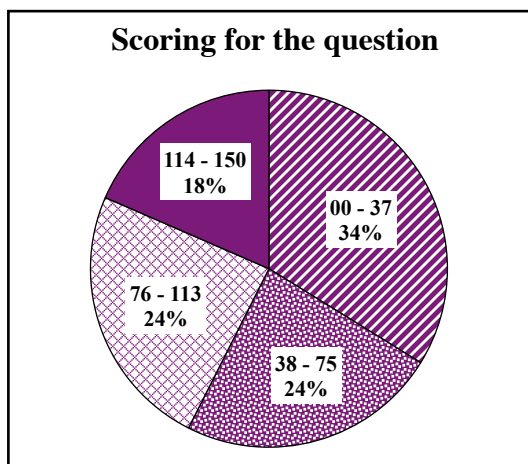

Question 7 has been selected by 51 % approximately. 150 marks are allocated for this question.

Out of it : in the interval 00 – 37 34 %
 in the interval 38 – 75 24 %
 in the interval 76 – 113 24 %
 in the interval 114 – 150 18 %

have scored marks.

For this question 18% have scored 114 marks or above whereas 34% of the candidates have scored 37 marks or below.

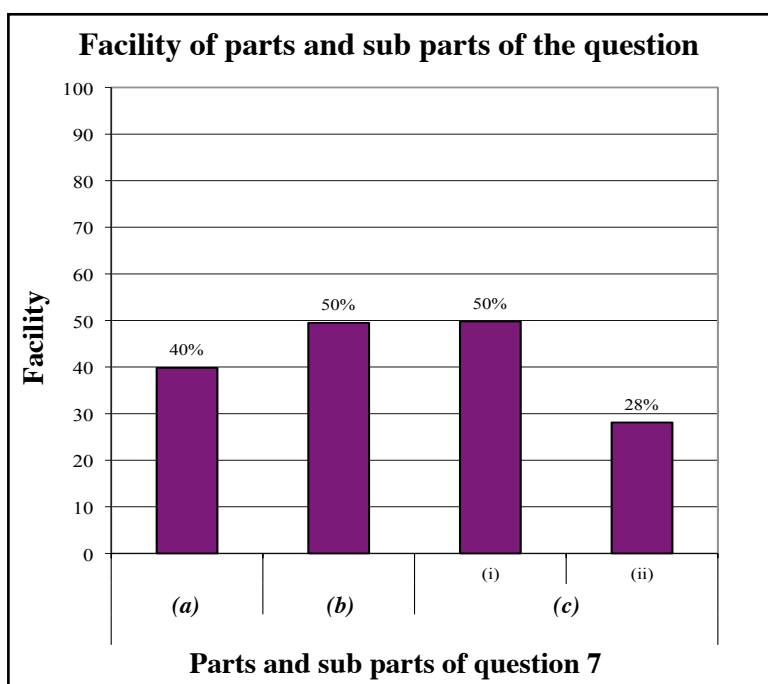

Out of 4 sub parts in this question the least facility has been shown by the sub part (c)(ii) and its facility is 28%. Facility of the parts (b) and (c)(i) are the same and their facility is 50%.

Out of the questions in part B of the paper II, this question is the one selected by the least number of candidates (51%) and its facility has been 46%. Though the part (a) of the question is an organic conversion done using Grignard reagent, it is required to prepare another Grignard reagent by using the Grignard reagent given. The competency level of the candidates can be uplifted by practicing more exercises related to such type of subject matter.

Though the facility shown by part (c)(i) has been 50% , the reason for the facility of part (c)(ii) to become approximately 28% is the negligence of the candidates for not concerning that alkyl halides undergo the elimination of HX molecule other than nucleophilic substitution undergo in the presence of OH⁻.

Question 8

8. (a) The compound **A** ($A = MX_n$, $M =$ a transition element that belongs to the $3d$ -block, $X =$ ligands of the same type) when treated with excess dilute NaOH followed by H_2O_2 gives a compound **B**. When an aqueous solution of **B** is acidified with dil. H_2SO_4 compound **C** is produced. **C** when reacted with NH_4Cl gives compound **D** as one of the products. Heating solid **D** gives a blue coloured compound **E**, water vapour and an inert diatomic gas **F**. Ca metal when burnt in gas **F** gives a white solid **G**. The reaction of **G** with water liberates a gas **H**. This gas forms white fumes with HCl gas. The metal Na reacts with liquid **H** to give a colourless diatomic gas **I** as one of the products. When an aqueous solution of **A** is treated with excess Na_2CO_3 , a coloured precipitate is formed. The precipitate is filtered and the filtrate is acidified with dil HNO_3 . Addition of $\text{AgNO}_3(\text{aq})$ to this solution gives a white precipitate which is soluble in dilute NH_4OH .
- Identify **A**, **B**, **C**, **D**, **E**, **F**, **G**, **H** and **I**.
 - What will you observe when a solution containing **C** is treated with dil. NaOH ? Give the balanced chemical equation relevant to this observation.

- (b) An aqueous solution **T** contains **three** metal ions. The following experiments were carried out to identify these metal ions.

Experiment	Observation
1. T was acidified with dilute HCl , and H_2S was bubbled through the clear solution obtained.	A black precipitate Q_1 was formed.
2. Q_1 was removed by filtration. The filtrate was boiled till all the H_2S was removed. The solution was cooled, and NH_4Cl and NH_4OH were added. H_2S was bubbled through the solution.	A clear solution was obtained. A black precipitate Q_2 was formed.
3. Q_2 was removed by filtration. The filtrate was boiled till all the H_2S was removed, and a solution of $(\text{NH}_4)_2\text{CO}_3$ was added.	A white precipitate Q_3 was formed.

Experiments for precipitates Q_1 , Q_2 and Q_3 .

Experiment	Observation
1. Q_1 was dissolved in hot dilute HNO_3 . After cooling, the solution was neutralized and KI was added.	A precipitate and a brown solution were formed.
2. Q_2 was dissolved in warm dilute HCl . The solution was cooled, and dilute NH_4OH was added. More dilute NH_4OH was added to this mixture.	A green precipitate was formed. The green precipitate dissolved giving a deep blue solution.
3. Q_3 was dissolved in conc. HCl and the solution was subjected to the flame test.	A green flame was obtained.

- Identify the **three** metal ions in solution **T**. (**Reasons are not required.**)
 - Write the chemical formulae of the precipitates Q_1 , Q_2 , and Q_3 .
- (c) The following procedure was used to determine the concentration of Al^{3+} ions in solution **U**.

Excess 8-hydroxyquinoline (commonly known as oxine, , $\text{C}_9\text{H}_7\text{ON}$) was added to 25.0 cm^3 of solution

U at $\text{pH} = 5$ to precipitate Al^{3+} ions as aluminium oxinate, $\text{Al}(\text{C}_9\text{H}_6\text{ON})_3$. The precipitate was filtered, washed with distilled water and dissolved in warm dilute HCl containing excess KBr . Thereafter, 25.0 cm^3 of $0.025 \text{ mol dm}^{-3}$ KBrO_3 was added to this solution. The reactions taking place in the above procedure are as follows:

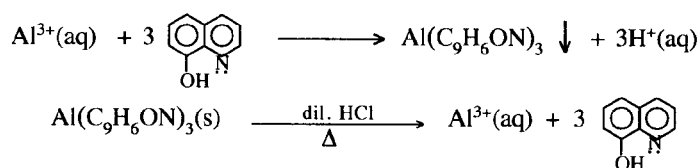

KBrO₃ is a primary standard for the generation of Br₂ in acidic medium.

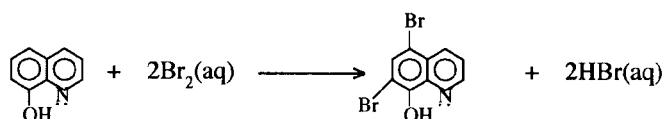
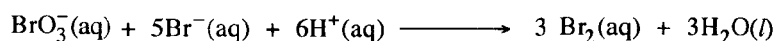

The excess Br₂ is reacted with KI to give I₃⁻. Then I₃⁻ was titrated with 0.05 mol dm⁻³ Na₂S₂O₃ using starch as the indicator. The volume of Na₂S₂O₃ required to reach the end point was 15.00 cm³.

Calculate the concentration of Al³⁺ in solution U in mg dm⁻³. (Al = 27)

8. (a) (i) A : CrCl₃ **or** CrCl₃.H₂O **or** [Cr(H₂O)₆]3Cl⁻
 B : Na₂CrO₄
 C : Na₂Cr₂O₇
 D : (NH₄)₂Cr₂O₇
 E : Cr₂O₃ (Award (05) for any chromium compound)
 F : N₂
 G : Ca₃N₂
 H : NH₃
 I : H₂

(05 × 9 = 45 marks)

- (ii) Orange solution C turns yellow (01 + 01)



8(a) : 50 marks

- (b) (i) T Contains : Cu²⁺, Ni²⁺, Ba²⁺ (10 + 10 + 10)

- (ii) Q₁ : CuS Q₂ : NiS Q₃ : BaCO₃ (07 + 07 + 06)

Note : (i) charges are required. (ii) mark independently.

8(b) : 50 marks

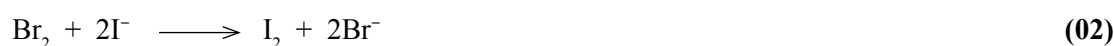
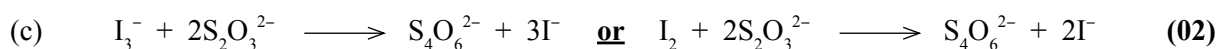

$$\text{Moles of S}_2\text{O}_3^{2-} = \frac{0.05}{1000} \times 15.0 \quad (03)$$

$$\text{Therefore, moles of I}_2 = \frac{1}{2} \times \frac{0.05}{1000} \times 15.0 \quad (03)$$

$$\text{Therefore, moles of excess Br}_2 = \frac{1}{2} \times \frac{0.05}{1000} \times 15.0 \quad (03)$$

$$= 3.75 \times 10^{-4} \quad (02)$$

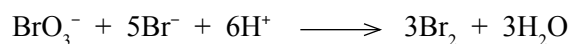

$$\text{Moles of BrO}_3^- = \frac{0.025}{1000} \times 25.0 \quad (03)$$

Therefore, moles of Br₂ produced by the above reaction

$$= 3 \times \frac{0.025}{1000} \times 25.0 \quad (03)$$

$$= 18.75 \times 10^{-4} \quad (02)$$

$$\text{Amount of Br}_2 \text{ reacted with oxine} = (18.75 \times 10^{-4}) - (3.75 \times 10^{-4}) \quad (03)$$

$$= 15 \times 10^{-4} \quad (02)$$

$$\text{Therefore, moles of oxine} = \frac{1}{2} \times 15 \times 10^{-4} \quad (03)$$

$$= 7.5 \times 10^{-4} \quad (02)$$

$$\text{Therefore, moles of Al}^{3+} = \frac{1}{3} \times 7.5 \times 10^{-4} \quad (03)$$

$$= 2.5 \times 10^{-4} \quad (02)$$

$$[\text{Al}^{3+}] = \frac{2.5 \times 10^{-4}}{25.0} \times 1000 \text{ mol dm}^{-3} \quad (03)$$

$$= \frac{2.5 \times 10^{-4}}{25.0} \times 1000 \times 27 \text{ g dm}^{-3} \quad (03)$$

$$= \frac{2.5 \times 10^{-4}}{25.0} \times 1000 \times 27 \times 1000 \text{ mg dm}^{-3} \quad (03)$$

$$= 270 \text{ mg dm}^{-3} \quad (03)$$

8(c) : 50 marks

Total for 8 : 150 marks

Overall observations, conclusions and suggestions regarding the answers to Question 8 :

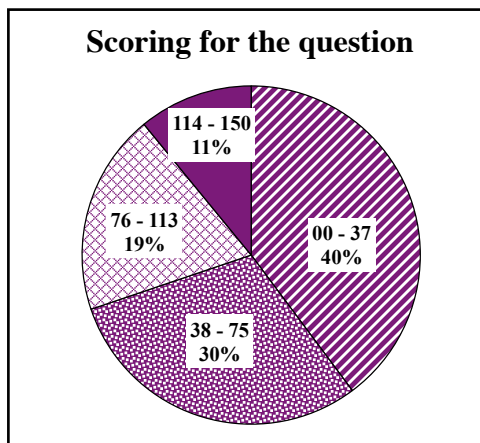

Out of the questions in part C of the paper II, this question is the one selected by the least number of candidates. That is 41%. 150 marks are allocated for this question.

Out of it :

in the interval	00 – 37	40%
in the interval	38 – 75	30%
in the interval	76 – 113	19%
in the interval	114 – 150	11%

have scored marks.

For this question 11% have scored over 114 marks or above while 40% of the candidates scored 37 marks or below.

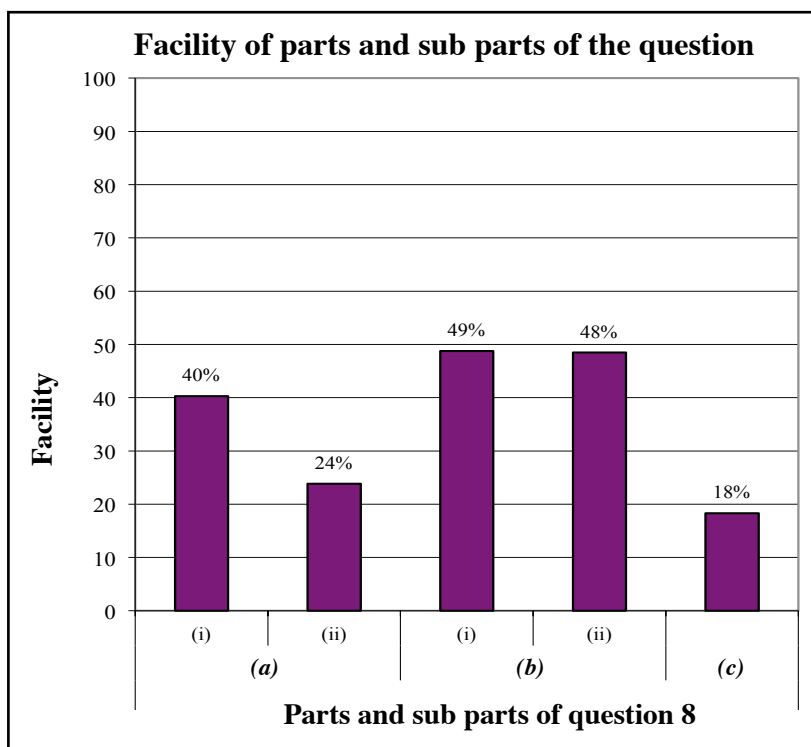

This question comprises 5 sub parts. Out of it facility of 2 sub parts is less than 25%. Sub part (b)(i) has been the easiest and its facility is 49%.

The least facility has been shown by the sub part (c) and its facility is 18%.

Out of the 10 questions in paper II of Chemistry, the least selected question by the candidates is this. The chemical formula and the compound given in part (c) being a complex one is the reason for that but if the question has been read properly and understood, it may not have been a difficult question. What needs there only is to do a suitable calculation by considering the stoichiometric ratio to get the answer.

As it is important to have an idea on the colours shown by the compounds of d block elements, facility can be increased by paying more attention on it.

Question 9

9. (a) A flow chart drawn by a final year university student to establish a chemical industry in the future in Sri Lanka is given below.

The following symbols are used to represent natural raw materials, manufacturing processes and products.

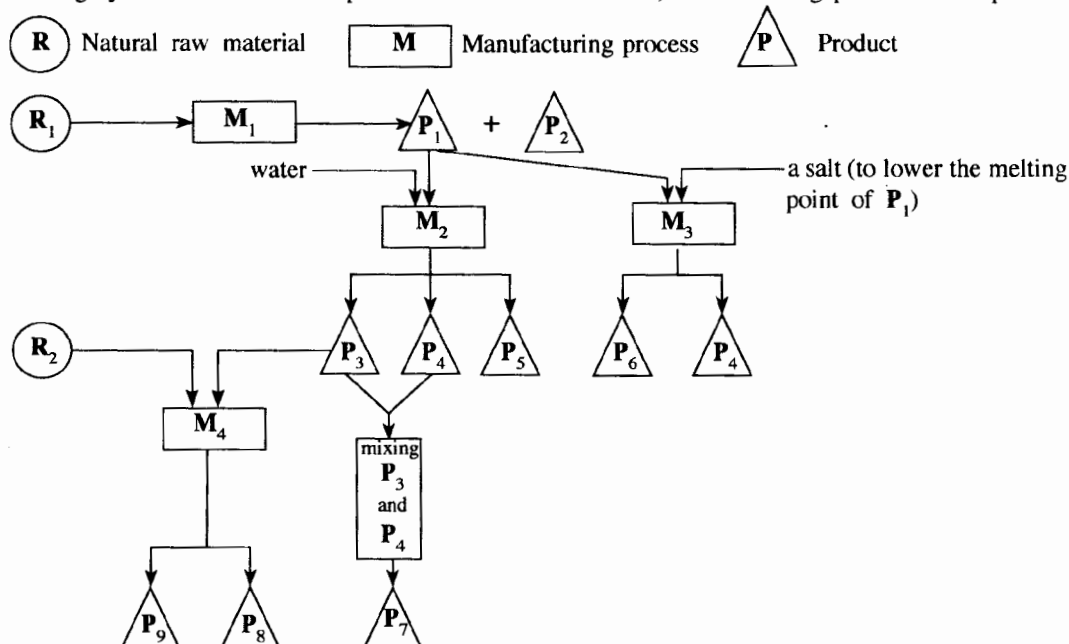

P_2 is used to produce a halogen that exists as a liquid at room temperature.

P_7 is used as a bleaching agent/strong oxidizing agent.

P_8 is used daily to maintain good hygiene.

- (i) Identify the **two** natural raw materials R_1 and R_2 .
 - (ii) Identify the **four** manufacturing processes M_1 , M_2 , M_3 and M_4 [e.g. manufacture of ammonia or Haber process]
 - (iii) Identify the products P_1 to P_9 .
 - (iv) Briefly describe the steps involved in processes M_1 and M_3 . (diagrams of equipment **not** required.)
 - (v) Draw and label the equipment used in the process M_2 .
 - (vi) Identify the salt used in the process M_3 .
 - (vii) Give **one** use for each of P_5 , P_6 and P_9 .
- (b) Answer these questions using the list given below.
- CO_2 , CH_4 , volatile hydrocarbons, NO, NO_2 , N_2O , NO_3^- , SO_2 , H_2S , CFC, $CaCO_3$, liquid petroleum and coal
- (i) Identify **two** gaseous species that are responsible for acid rain and briefly explain, with the aid of balanced chemical equations, how these species cause acid rain.
 - (ii) Acid rain has harmful effects on the environment. Briefly discuss this statement
 - (iii) Identify **three** species that are emitted to the environment due to the burning of fossil fuel, along with one adverse environmental issue for each.
 - (iv) "The existence of trace amounts of industrial synthetic species in the atmosphere can cause adverse environmental issues." Explain this statement using CFC as an example.
 - (v) Identify **five** greenhouse gases and state a human activity by which each of these gases enters the atmosphere.
 - (vi) Briefly explain using balanced chemical equations, how a natural substance (select from the list) can be used to remove acidic gases emitted during the burning of fossil fuel.

9. (a) (i) R_1 : Sea water (03)
 R_2 : Oil / Fats / Coconut oil / Vegetable oil (03)
- (ii) M_1 : Manufacture of salt (03)
 M_2 : Manufacture of NaOH (03)
 M_3 : Manufacture / extraction of Na (Downs cell method) (03)
 M_4 : Manufacture of soap (03)
- (iii) P_1 : NaCl (03)
 P_2 : Bittern solution / Mother liquor / $MgBr_2$ (03)
 P_3 : NaOH (03)
 P_4 : Cl_2 (03)
 P_5 : H_2 (03)
 P_6 : Na (03)
 P_7 : $NOCl$ / Milton solution (03)
 P_8 : Soap (03)
 P_9 : Glycerol / Glycerine (03)

(iv) **Process M_1**

Sea water evaporated in three tanks (01)

1st tanks : $CaCO_3$ precipitates (01) Remaining solution transferred to 2nd tank. (01)

2nd tank : $CaSO_4$ precipitates (01) Remaining solution transferred to 3rd tank. (01)

3rd tank : NaCl precipitates (01) Remaining solution (Bittern) is removed. (01)

Note : Explanation could be given as a diagram.

Process M_3

Electrolysis of molten NaCl with added $CaCl_2$ (01)

At the cathode $Na^+(l) + e \longrightarrow Na(l)$ (02)

At the anode $2Cl^-(l) \longrightarrow Cl_2(g) + 2e$ (02)

Cathode and anode are separated by a steel gauze diaphragm to prevent Na from reacting with Cl_2 gas (02)

Note : Physical states are required in equations.

(v)

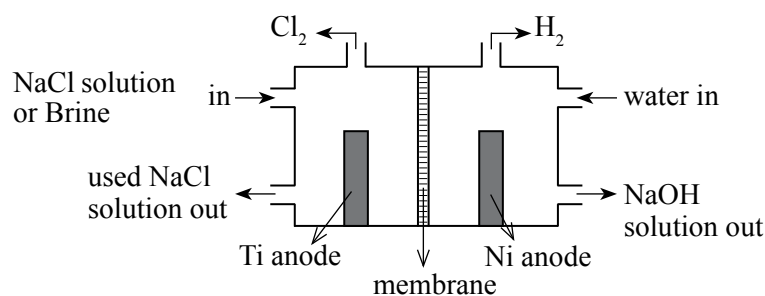

Note : Mark independently.

(01 marks \times 9 + 01 for correct sketch of cell = 10 marks)

Alternate answer :

Diaphragm Cell

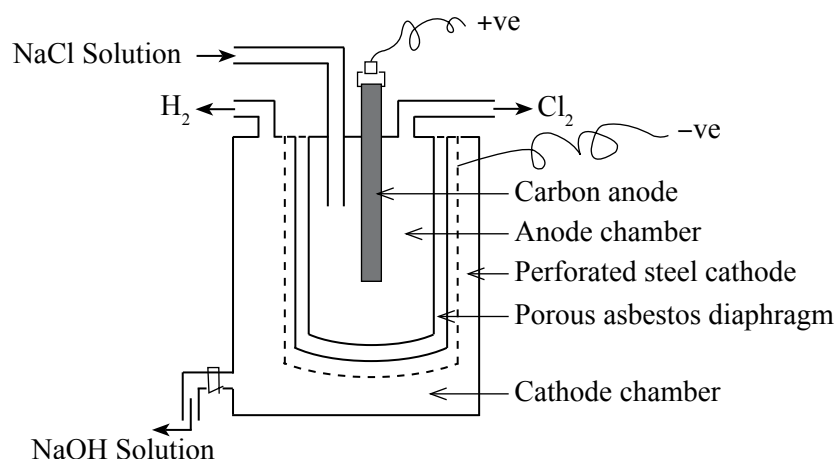

(01 marks × 9 + 01 for correct sketch of cell = 10 marks)

(vi) CaCl_2 (03)

(vii) P_5 : fuel / to manufacture HCl / to manufacture margarine /
in weather balloons/ manufacture of NH_3 (01)

P_6 : Sodium vapour lamps/ synthesis of NaNH_2 / to dry organic solvents /
as a coolant in nuclear reactors (01)

P_9 : to manufacture cosmetics / to manufacture TNG (explosives) (01)

9(a) : 75 marks

(b) (i) $\text{NO}_2, \text{SO}_2, \text{NO}$ (02 + 02)

From NO :

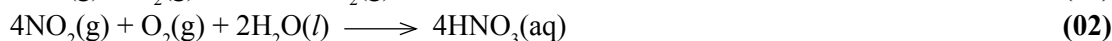

From NO_2 :

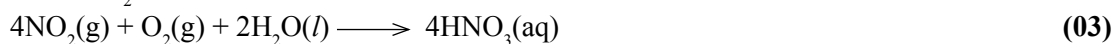

From SO_2 :



or

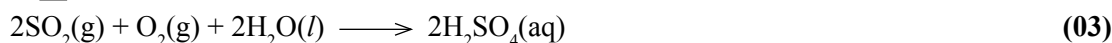

(Generation of acid rain by any two sets of reactions given above, 05 marks × 2 = 10marks)

Note : Physical states are not required.

(ii) Points to be included :

- Damage to plants
- $\text{HNO}_3/\text{H}_2\text{SO}_4$ dissolves aluminosilicates on Earth to give free Al^{3+} which leaches into water and interferes with the operation of fish gills resulting in the death of fish.
- Washes out nutrients from soil
- Degrades metallic structures (e.g. vehicles, bridges, buildings, statues)
- Hardness of water increases
- Concentration of heavy metals in water increases
- Composition of Earth's surface changes (e.g. due to solubility of dolomite, limestone, marble, sand and rock /oxidation of minerals such as sulfides)

Any five (02 marks × 5 = 10 marks)

(iii) SO_2 , NO, NO_2 , CO_2 , Volatile hydrocarbons **(any three)** **(02 + 02 + 02)**

Global warming - CO_2 , Volatile hydrocarbons **(02 + 01)**

Acid rain - SO_2 , NO **(02 + 01)**

Photochemical smog - NO, hydrocarbons **(02 + 01)**

- (iv) • CFCs are industrial gases that are used as coolants in refrigerators, air conditioners and spray cans.
- CFCs are released into the atmosphere during usage and repair of these equipment.
 - CFCs are highly stable trace gasses in the atmosphere.
 - Therefore, CFCs are persistent gasses in the atmosphere.

and

- CFCs produce in the higher atmosphere (stratosphere) in the presence of high energy UV radiation.
- The increases the rate of depletion of ozone by acting as a catalyst.
- The reduction of ozone allows harmful UV rays to reach the surface of the planet.
- Exposure to harmful UV radiation results in cancers, gene mutations and cataracts.

or

- CFC is a strong greenhouse gas.
- CFCs contribute to global warming.
- CFCs absorb IR radiation emitted from the surface of the planet.
- Global warming results in climate change.

(02 × 8 = 10 marks)

(v) CO ₂	: (fossil) fuel burning	(01 + 01)
CH ₄	: wet land agriculture/ animal farms/ improper waste disposal	(01 + 01)
NO ₂	: Burning at high temperatures	(01 + 01)
CFCs	: air conditioners/ refrigerators/ spray guns	(01 + 01)
N ₂ O	: agriculture (use of nitrogen fertilizer)	(01 + 01)
H ₂ S	: Anaerobic digestion of sulfur containing substances such as coconut husks	(01 + 01)
SO ₂	: fossil fuel burning	(01 + 01)
Volatile hydrocarbons – fossil fuel burning , natural gas extraction, transportation		(01 + 01)
Any five (02 × 5 = 10 marks)		

(vi) Limestone (CaCO ₃) decomposes to get CaO (lime) and CO ₂ .	(02)
$\text{CaCO}_3 \xrightarrow{\Delta} \text{CaO} + \text{CO}_2$	(03)
CaO then reacts with the SO ₂	(02)
$\text{CaO} + \text{SO}_2 \longrightarrow \text{CaSO}_3$	(03)

Note : If only equation is given 05 marks

or

Slurry of lime stone is used to absorb or scrub SO ₂ .	(05)
$\text{CaCO}_3 + \text{SO}_2 \longrightarrow \text{CaSO}_3 + \text{CO}_2$	(05)

9(b) : 75 marks

Total for 9 : 150 marks

Overall observations, conclusions and suggestions regarding the answers to Question 9 :

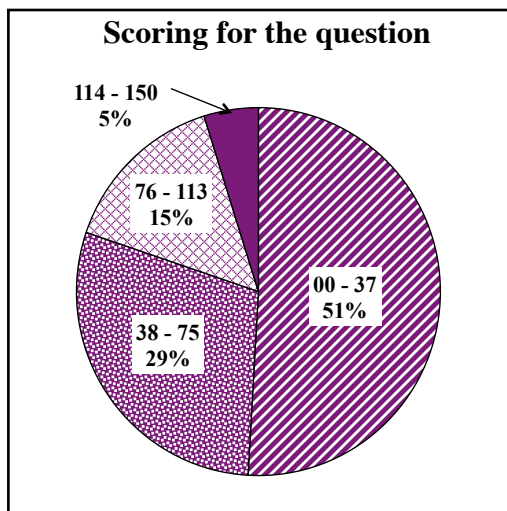

Question 9 is selected by 76% of candidates. 150 marks are allocated for this question. Out of the six questions in part B and C in Chemistry this is the question with highest selection done by the candidates.

Out of it : in the interval 00 – 37 51 %
in the interval 38 – 75 29 %
in the interval 76 – 113 15 %
in the interval 114 – 150 5 %

have scored marks.

For this question 5% have scored over 114 marks or above, while 51% of the candidates scored 37 marks or below.

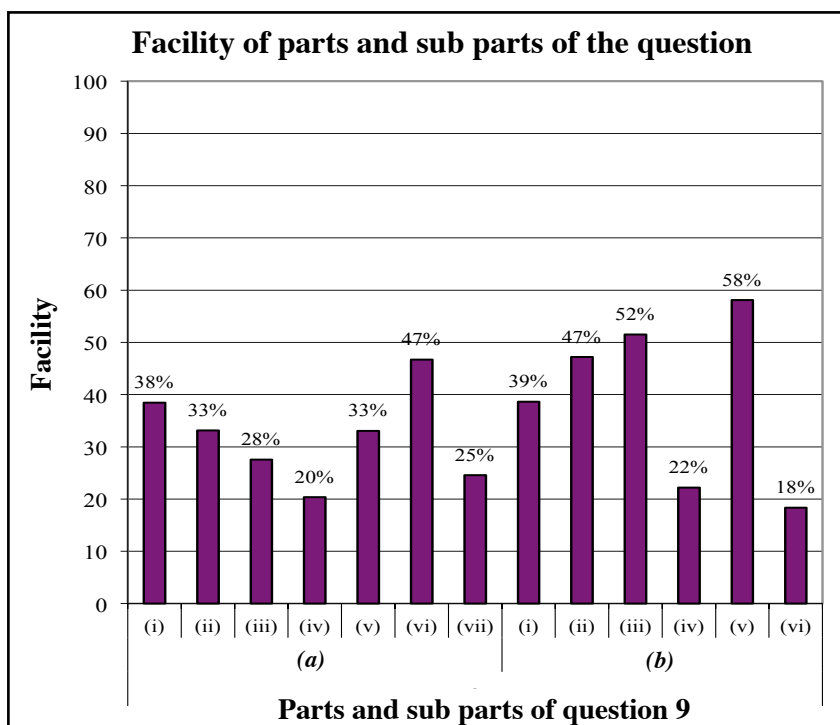

This question comprises 13 sub parts. Out of it facility of 7 sub parts is less than 35%. Sub part (b)(v) has been the easiest and its facility is 58%.

The least facility has been shown by the sub part (b)(vi) and its facility is 18%.

Though question 9 gets highest selection in almost every year, the relative competency level shown by the candidates is low. The facility shown has been approximately 35 % this year. It is explained by 51% of the candidates obtaining below 37 marks.

For the sub part (a)(iv) approximately 20% has shown least facility. Production process should have been identified correctly there. Though the question is simple, failure in the understanding of it is the reason for its least facility.

Understanding of the integrated process given in part (a) properly, it is required to have a proper study on the industries prescribed.

As a whole, answers provided for part (b) is satisfactory because environmental pollution has become a current issue and always being talked. But the part (b)(vi) has shown the least facility of 18% because its question is related to the modern technology. As it proves the importance of seeking the modern knowledge, candidates should pay much attention for such facts.

Question 10

10. (a) **X, Y and Z** are coordination compounds. They have an octahedral geometry. The atomic composition of the species in the coordination sphere (i.e. metal ion and the ligands coordinated to it) in **X, Y and Z** are $\text{FeH}_{10}\text{CNO}_5\text{S}$, $\text{FeH}_8\text{C}_2\text{N}_2\text{O}_4\text{S}_2$ and $\text{FeH}_6\text{C}_3\text{N}_3\text{O}_3\text{S}_3$ respectively. The oxidation state of the metal ion in all three compounds is the same. In each compound, **two types** of ligands are coordinated to the metal ion. If these compounds contain **non-coordinated** anions, they are of the same type.

An aqueous solution **S** contains **X, Y and Z** in the molar ratio 1:1:1. The concentration of **each** compound in solution **S** is 0.10 mol dm^{-3} . When excess AgNO_3 solution was added to 100.0 cm^3 of **S**, a yellow precipitate was formed. The precipitate was washed with water and oven dried to a constant mass. The mass of the precipitate was 7.05 g . This precipitate does not dissolve in conc. NH_4OH .

(Relative molecular mass of the chemical compound in the yellow precipitate = 235)

- Identify the ligands coordinated to the metal ions in **X, Y and Z**.
- Write the chemical formula of the yellow precipitate.
- Giving reasons, determine the structures of **X, Y and Z**.
- Given below is the structure of ethylenediamine (en)

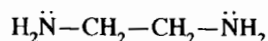

Ethylenediamine coordinates to the metal ion M^{3+} through the two nitrogen atoms, to form the complex ion **Q** (i.e. metal ion and ligands coordinated to it). **Q** has an octahedral geometry.

Write the structural formula of **Q** and draw its structure.

Note: Consider that only ethylenediamine is coordinated to the metal ion. Use the abbreviation 'en' to denote ethylenediamine in your structural formula.

- (b) You are provided with the following.

- 1.0 mol dm^{-3} aqueous solutions of $\text{Al}(\text{NO}_3)_3$, $\text{Cu}(\text{NO}_3)_2$ and $\text{Fe}(\text{NO}_3)_2$
- Al, Cu and Fe metal rods
- Chemicals required to use in salt bridges
- Conducting wires and beakers

In addition to the above, the following data is also provided.

$$E_{\text{Fe}^{2+}/\text{Fe}}^{\circ} = -0.44 \text{ V}, \quad E_{\text{Al}^{3+}/\text{Al}}^{\circ} = -1.66 \text{ V}, \quad E_{\text{Cu}^{2+}/\text{Cu}}^{\circ} = +0.34 \text{ V}$$

- Diagram the **three** electrochemical cells that can be constructed using the above materials. Indicate the anode and cathode along with their signs in each cell.
- For each electrochemical cell drawn in part (i) above
 - give the cell notation.
 - determine E_{cell}° .
 - give balanced chemical equations with physical states for the electrode reactions.
- Giving reasons, explain which of the following compounds is/are appropriate to use in salt bridges.

NaOH , NaNO_3 , acetic acid
- Consider the electrochemical cell which shows the highest E_{cell}° initially. Assume that this electrochemical cell has been constructed using equal volumes of the relevant solutions in each compartment and their volumes do not change during the experiment.

The two electrodes of this cell were connected using a conducting wire and after some time, the concentration of metal ions in the anode compartment was found to be C mol dm^{-3} . Express the concentration of metal ions in the cathode compartment in terms of **C**.

10.(a) (i) $\text{SCN}^- / \text{NCS}^-$ and H_2O (05 + 05)

(ii) AgI (05)

(iii) Based on the atomic composition;

coordination sphere of X : $[\text{Fe}(\text{H}_2\text{O})_5(\text{SCN})]$ or $[\text{Fe}(\text{SCN})(\text{H}_2\text{O})_5]$ (05)

coordination sphere of Y : $[\text{Fe}(\text{H}_2\text{O})_4(\text{SCN})_2]$ or $[\text{Fe}(\text{SCN})_2(\text{H}_2\text{O})_4]$ (05)

coordination sphere of Z : $[\text{Fe}(\text{H}_2\text{O})_3(\text{SCN})_3]$ or $[\text{Fe}(\text{SCN})_3(\text{H}_2\text{O})_3]$ (05)

Note: (NCS) could be used instead of (SCN). Could be written as either H_2O or OH_2 .

Number of moles of each compound (i.e. X, Y, Z) in $100 \text{ cm}^3 = (0.1/1000) \times 100$
= 0.01 (05)

Relative molecular mass of AgI = 235

Therefore, number of moles of AgI (or I⁻) in the precipitate = $7.05/235 = 0.03$ (05)

If oxidation state of Fe is +3 ;

X : Charge of complex is +2. Hence, two I⁻. (02)

Y : Charge of complex is +1. Hence, one I⁻. (02)

Z : Complex has no charge. Hence, no I⁻. (02)

Therefore, oxidation state of Fe has to be +3. (04)

or

If oxidation state of Fe is +2;

X : Charge of complex is +1. Hence, one I⁻. (02)

Y : Charge of complex is zero. Hence, will not have any I⁻. (02)

Z : Charge of complex is -1. Hence, will not have any I⁻. (02)

Therefore, oxidation state of Fe cannot be +2. It has to be +3. (04)

Structural formulae:

X : $[\text{Fe}(\text{H}_2\text{O})_5(\text{SCN})]\text{I}_2$ or $[\text{Fe}(\text{SCN})(\text{H}_2\text{O})_5]\text{I}_2$ (05)

Y : $[\text{Fe}(\text{H}_2\text{O})_4(\text{SCN})_2]\text{I}$ or $[\text{Fe}(\text{SCN})_2(\text{H}_2\text{O})_4]\text{I}$ (05)

Z : $[\text{Fe}(\text{H}_2\text{O})_3(\text{SCN})_3]$ or $[\text{Fe}(\text{SCN})_3(\text{H}_2\text{O})_3]$ (05)

Note:

- (NCS) could be used instead of (SCN). No marks for (CNS) / CSN). H_2O could be written as OH_2 .
- If the coordination spheres of X, Y, Z are not written but the structural formulae of X, Y, Z are written, award the (05 + 05 + 05) for the correct structural formulae and the marks allocated for the respective coordination sphere (05 + 05 + 05).

(iv) $(M(en)_3)^{3+}$

(05)

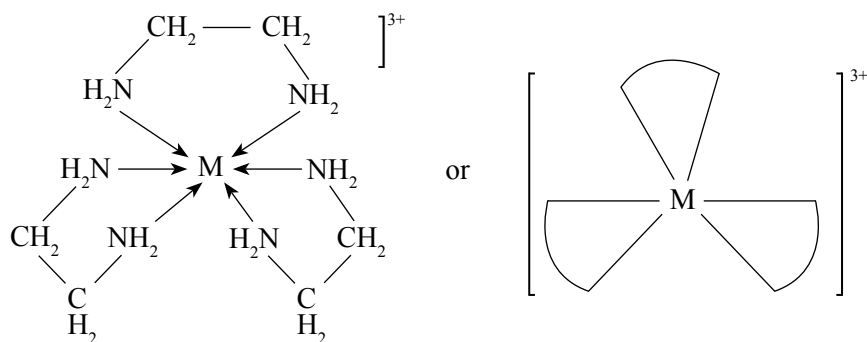

(05)

Note : Charge of the complex is required for the award of marks.

10(a) : 75 marks

(b) (i)

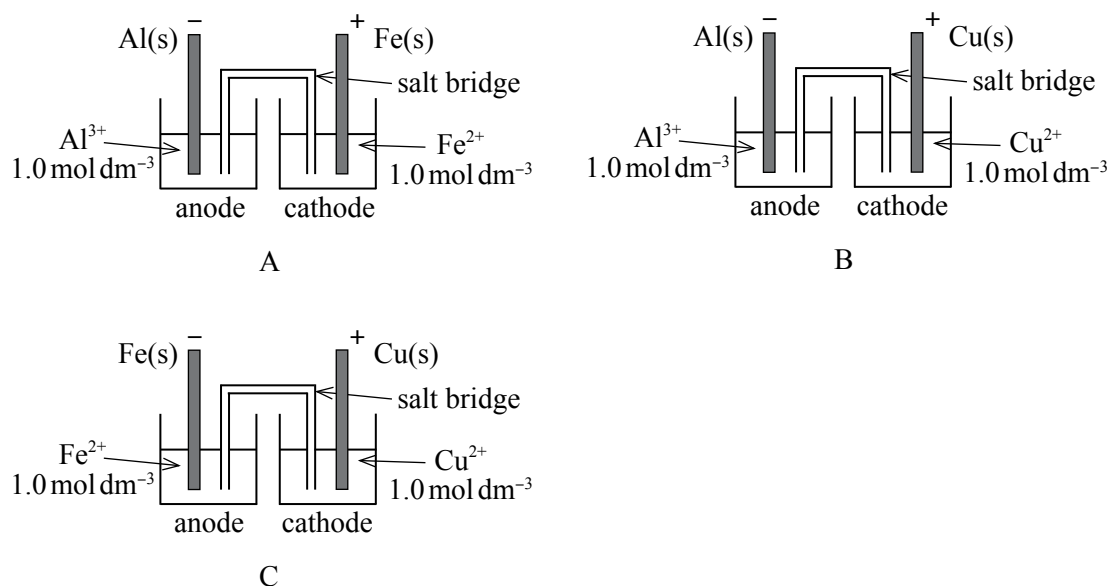

For each electrode;

- Display and identification of metal strip (01)
- Identification of the solution (01)
- Display of correct charge (01)
- Correct labeling as anode or cathode (01)
- Display of the salt bridge (01)

Note : Mark each electrode individually, If a voltmeter is drawn, do not deduct marks.
If a battery or an external voltage source is connected, do not award marks.
If the electrodes are connected by a wire deduct 02 marks.

(27 marks for 3 cells)

- (ii) I. Cell A : $\text{Al(s)} | \text{Al}^{3+}(\text{aq}, 1.0 \text{ mol dm}^{-3}) || \text{Fe}^{2+}(\text{aq}, 1.0 \text{ mol dm}^{-3}) | \text{Fe(s)}$ (02)
 Cell B : $\text{Al(s)} | \text{Al}^{3+}(\text{aq}, 1.0 \text{ mol dm}^{-3}) || \text{Cu}^{2+}(\text{aq}, 1.0 \text{ mol dm}^{-3}) | \text{Cu(s)}$ (02)
 Cell C : $\text{Fe(s)} | \text{Fe}^{2+}(\text{aq}, 1.0 \text{ mol dm}^{-3}) || \text{Cu}^{2+}(\text{aq}, 1.0 \text{ mol dm}^{-3}) | \text{Cu(s)}$ (02)

II. $E_{\text{cell}}^0 = E_{\text{cathode}}^0 - E_{\text{anode}}^0$ $E_{\text{cell}}^0 = E_{\text{RHS}}^0 - E_{\text{LHS}}^0$ (03)

Cell A

$E_{\text{cell}}^0 = -0.44 \text{ V} - (-1.66 \text{ V})$ (02)
 $= 1.22 \text{ V}$ (01 + 01)

Cell B

$E_{\text{cell}}^0 = 0.34 \text{ V} - (-1.66 \text{ V})$ (02)
 $= 2.00 \text{ V}$ (01 + 01)

Cell C

$E_{\text{cell}}^0 = 0.34 \text{ V} - (-0.44 \text{ V})$ (02)
 $= 0.78 \text{ V}$ (01 + 01)

- III. Cell A : $\text{Al(s)} \rightleftharpoons \text{Al}^{3+}(\text{aq}) + 3\text{e}$ (01)
 $\text{Fe}^{2+}(\text{aq}) + 2\text{e} \rightleftharpoons \text{Fe(s)}$ (01)

- Cell B : $\text{Al(s)} \rightleftharpoons \text{Al}^{3+}(\text{aq}) + 3\text{e}$ (01)
 $\text{Cu}^{2+}(\text{aq}) + 2\text{e} \rightleftharpoons \text{Cu(s)}$ (01)

- Cell C : $\text{Fe(s)} \rightleftharpoons \text{Fe}^{2+}(\text{aq}) + 2\text{e}$ (01)
 $\text{Cu}^{2+}(\text{aq}) + 2\text{e} \rightleftharpoons \text{Cu(s)}$ (01)

Note : Do not award marks if \longrightarrow is used instead of \rightleftharpoons Physical states are required.

- (iii) NaOH - not suitable, metal hydroxides can be formed. (02)
 NaNO₃ - suitable, good ionic conductivity OR (02)
 (not suitable because ionic conductivities of Na⁺ and NO₃⁻ are different)
 Acetic acid - not suitable, weakly ionized, low conductivity (02)

Alternate answer - 1

- None of the given compound is suitable. (03)
 NaOH - metal hydroxide can be formed (01)
 NaNO₃ - mobility / conductivity of two ions are different (01)
 Acetic acid - weakly ionized / low conductivity (01)

Alternate answer - 2

- Only NaNO₃ is suitable (03)
 Due to its good ionic conductivity, does not participate in electrode reactions (03)

(iv) Selection of the correct pair of electrodes (03)

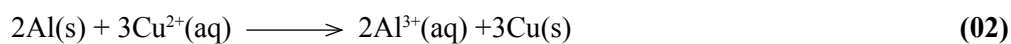

(Physical states and stoichiometry must be correct.)

Initial (mol dm ⁻³)	1.0	1.0	
After time, t (mol dm ⁻³)	(1 - 3x/V)	(1 + 2x/V)	
Where V= Volume		(02)	(02)

$$[\text{Al}^{3+}] = 1 + 2x/V = c \quad (03)$$

$$x/V = (c - 1)/2$$

$$[\text{Cu}^{2+}] = 1 - 3(c - 1)/2 \quad (03)$$

$$= (5 - 3c)/2$$

or

Selection of the correct pair of electrodes (03)

Assume the concentration of [Al³⁺] increased during time t = c₁ mol dm⁻³

$$\text{Then } [\text{Al}^{3+}] = 1 + c_1 = c \quad (03)$$

$$\text{Concentration of } [\text{Cu}^{2+}] \text{ increased during time} = 3c_1/2 \text{ mol dm}^{-3} \quad (03)$$

$$\text{Therefore } [\text{Cu}^{2+}] = 1 - 3c_1/2 \quad (03)$$

$$= 1 - 3(c - 1)/2 \quad (03)$$

$$= (5 - 3c)/2$$

10(b) : 75 marks

Total for 10 : 150 marks

Overall observations, conclusions and suggestions regarding the answers to Question 10 :

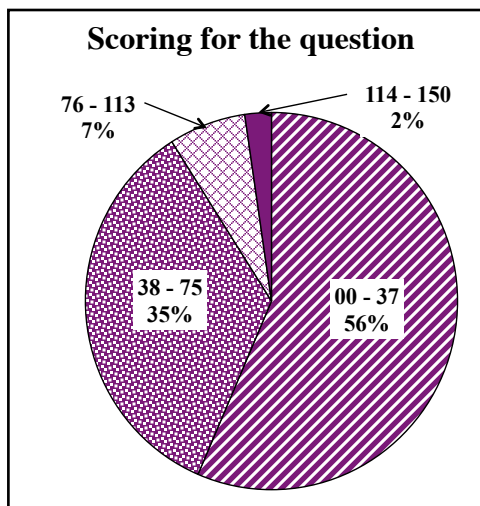

Question 10 is selected by 50% of the candidates approximately. 150 marks are allocated for this question.

Out of it :

in the interval	00 – 37	56%
in the interval	38 – 75	35%
in the interval	76 – 113	7%
in the interval	114 – 150	2%

have scored marks.

For this question 2% have scored 114 marks or above whereas 56% of the candidates have scored 37 marks or below.

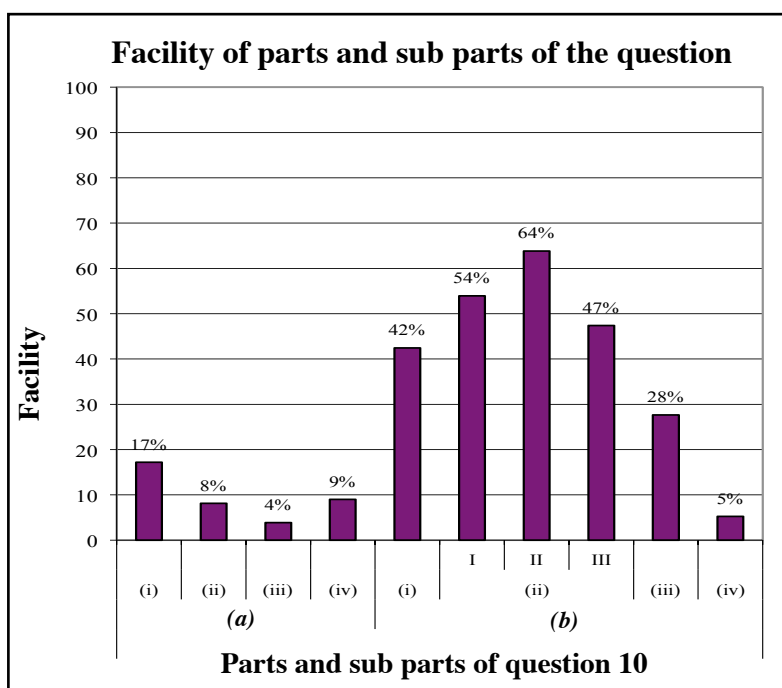

Question 10 comprises 10 sub parts and its overall facility is 26%. There are 5 sub parts with less than that facility. The least facility has been shown by the sub part (a)(iii) and its facility is 4%. Sub part (b)(ii) has become the easiest and its facility is 64%.

Facility of all four sub parts in the part (a) of question 10 is less 20%. Therefore the overall facility of its all the parts is 9.5%. This part of the question is regarding the co-ordinate complexes formed by the 'd' block elements in the periodic table.

Instead of the familiar chemical formulae the atomic composition of the species are given in the question. Candidates have not been able to select the suitable ligands by observing them properly in accordance with the observations given. Instead of the familiar mono dentate ligands as it is given bidentate ligands in the question, candidates have not been able to apply their knowledge in the relevant way resulting a very low competency level in the marks scored.

Out of the 6 sub parts in part (b) belongs to electro chemistry, except for parts (iii) and (iv) as th facility for other sub parts are above 40 %, regarding those moderate competency level has been shown by the candidates. Part (iv) which is asked on an electro chemical cell shows very low facility below 5%. Reason for low competency level is not identifying the anode, cathode and the cell reaction correctly in the cell. It is important to practice this type of problems more during the teaching – leaning process.

2.2.4 Overall observations, conclusions and suggestions regarding the answers to Paper II

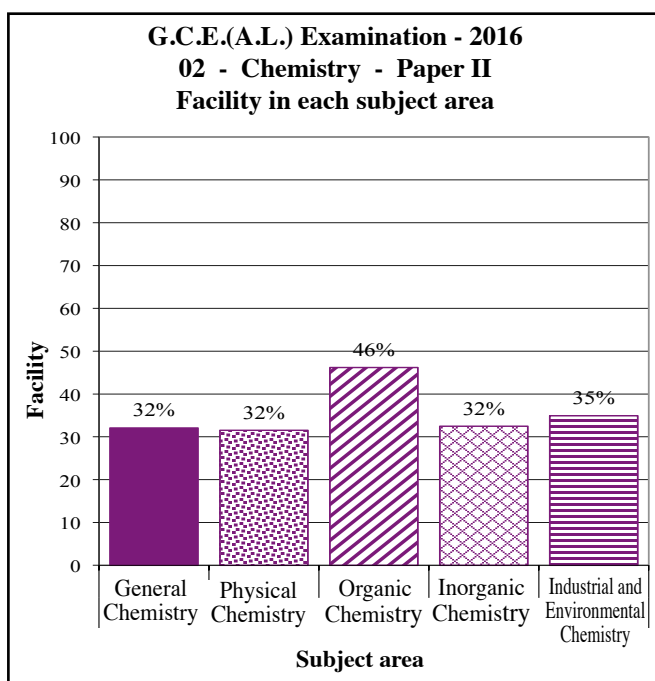
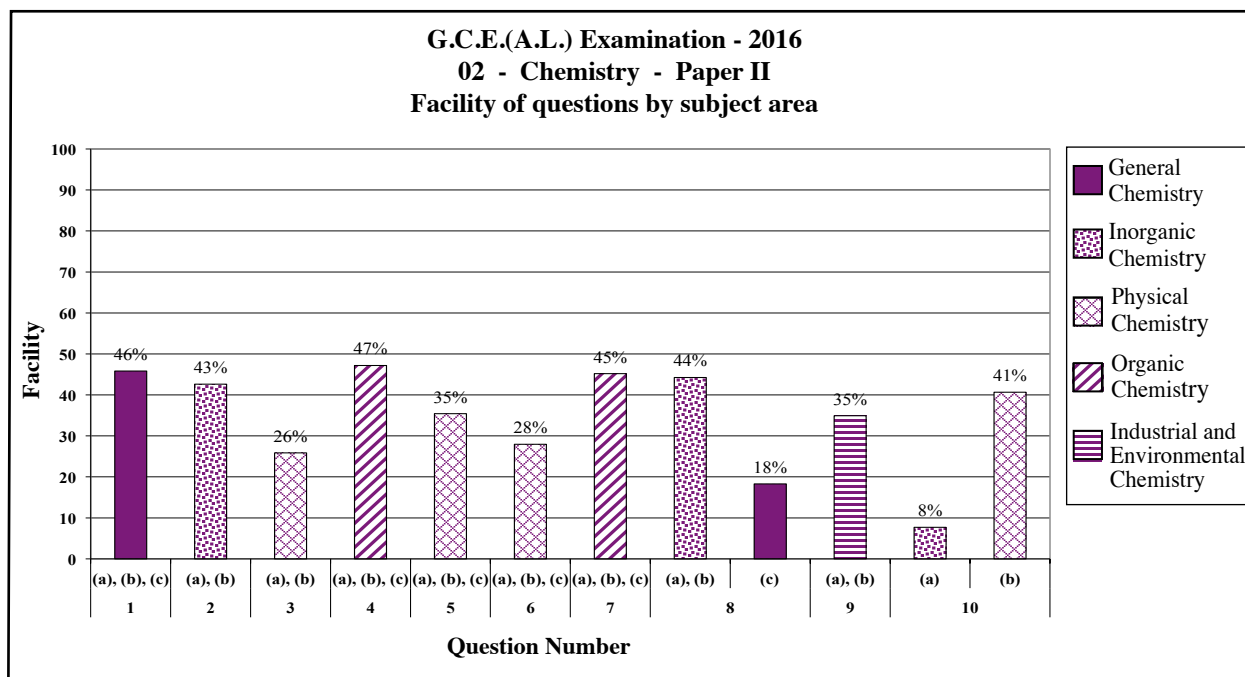

The facility of different subject areas of Chemistry II Paper in G.C.E. (A/L) Exam are as follows

General Chemistry	32 %
Inorganic Chemistry	32 %
Physical Chemistry	32 %
Organic Chemistry	46 %
Industrial and environmental Chemistry	35 %

The overall facility of Chemistry paper II about 35%. The facility of three areas General Chemistry, inorganic Chemistry and Physical Chemistry is the same (32%). Highest facility has been shown for Organic Chemistry. It is 46%.

As in the last year the highest facility is shown in the area of organic chemistry, which is 46%. Though the facility of all the other subject areas is slightly less than 46%, becoming approximately the same is specially highlighted. As a whole it shows that the facility of paper II has increased than the last year.

Question 1 and 8 (c) in paper II are related to the subject area of General Chemistry and their facilities are 46% and 18% respectively. Sub part 8(c) is a simple problem to be solved using stoichiometry but the structures of the compounds given in the equations are not being used frequently in the syllabus as well not being the familiar compounds, the question is skipped by the candidates without reading it, has made its facility decreased to 18%. The low facility 8% shown in question 10(c) is also because of not trending to provide answers to the question as it is not a familiar type problem to the candidates.

Part III

3 Facts to be considered when answering questions and suggestions :

3.1. Facts to be considered when answering :

Common instructions :

- * The candidates should read and understand well the basic instructions given in the question paper. They should be considerate as to the facts such as how many questions be answered in each section, which questions are compulsory, what time is affordable and how much marks are allocated. They should also read the questions carefully and select the questions with a clear mind set.
- * When responding to the questions in Paper I, one option which is the most correct needs to be selected. Also, one cross must be placed clearly.
- * When answering questions in Paper II, every new question should be started in a new page.
- * Answers should be written in clear and correct handwriting.
- * The candidate's` index number should be written on every page in the relevant box.
- * Numbers of questions, parts and sub parts should be indicated correctly.
- * Long descriptions shouldn't be given when short specific answers are expected. Similarly short answers should be avoided in places where descriptive answers are preferred.
- * According to the way the question is posed, facts should be presented logically and analytically.
- * When answering paper II, all the sub parts given under the main question should be read carefully and only the target answer relevant to each sub part should be presented.
- * Care should be taken to manage time properly when answering questions.
- * Candidates should use blue or black pens to write answers and should avoid using red and green pens.
- * When the bell starts ringing indicating that the time set apart for writing is about to be over, all the answer scripts should be arranged and tied up properly.
- * In order to manage time more effectively, it is better to answer the easier questions first and then more difficult ones rather than answering them in the given sequence.

Special instructions :

Generally when consider the principles of the subject based on which the questions set in paper I and II and when analyze the selection of responses in paper I by the students, following suggestions can be introduced to uplift the competency level of the students.

For the area of organic chemistry special attention should be paid on the following facts.

- * Studying comparatively on the different products formed by the reduction of 'N' containing compounds by LiAlH_4 and NaBH_4 .
- * Studying comparatively on the reactions done by Grignard reagent with esters and alkynes containing acidic hydrogen.
- * Illustrating suitable examples for clear understanding of the words such as enantiomers and diastereomers related to the concept isomerism.
- * Clearly understanding the variation of the acidity of the organic compounds containing different functional groups such as $-\text{COOH}$, , $-\text{CH}_2\text{OH}$.
- * Drawing the structure of the organic compounds containing more than one functional groups and explaining their three-dimensional existence.
- * When identifying the organic compounds using various reagents in the reactions, asking students not only to pay attention on the observations but also to write the appropriate chemical equations. For examples reactions done with Brady's reagent, Fehling's reagent and Tollen's reagent.
- * Instead of by-hearting the organic mechanisms giving a better explanation on transferring of electrons, breaking bonds, forming bonds, steric-effects by three-dimensional models etc.

For the area of physical chemistry special attention should be paid on the following facts.

- * When solving the problems using chemical equations those should be correctly balanced in accordance with the stoichiometric ratio, write the physical states of reactants/products and use the relevant chemical principles and practice the way to get the correct answer by doing more exercises considering all those facts together.
- * Always when using physical parameters along with their numerical values stating the correct units and converting the units correctly.
- * Solving problems containing both symbols as well as numerical values.
- * Solving problems related to logarithm and anti-logarithm.
- * Giving correct understanding about extensive properties and intensive properties.

- * Avoiding the difficulty in constructing the mutual relationship between the chemical principles.

Examples :

- Equilibrium and rate of reactions
- ΔH , ΔS , ΔG and spontaneity of reactions
- Chemical reactions and phase equilibrium
- Le Chatelier's principle and its applications
- Structures of the organic compounds, functional groups, knowledge of polarity using in the calculations such as distribution coefficient

For the area of General/ Inorganic/ Industrial and Environmental Chemistry special attention should be paid on the following facts.

- * When analyzing the data obtained from practical experiments developing the ability of illustrating those by appropriate reactions and balanced chemical equations.

Examples :

- Reactions forming coloured compounds / complexes
- Identification reactions

- * Developing the knowledge on reactions, colour and the oxidation number of the central atom in inorganic co-ordinate complexes.

- * Focusing attention on the correct steps to be followed in drawing the Lewis structures and resonance structures. (lone pair electrons, formal charges etc.)

- * Giving better knowledge on the variation of the bond angles related to the electron pair repulsion and electro-negativity.

Examples :

- NH_3 and NF_3
- H_2O and H_2S

- * Making them understand the relationship between the stability of the ions and the electron configuration.

3.2. Comments and suggestions about the teaching learning process :

- * As the ability answering questions related to practical activities is generally low, students should be engaged in practical activities during the learning teaching process.
- * Principles should be tried to teach as nature of models in Chemistry to be highlighted.
- * Students are not required to by heart all the concepts in chemistry but they should be oriented to solve problems applying them correctly at relevant instances.
- * Since a large number of compounds are studied under organic chemistry more attention should be paid for the preparation of short notes creatively and work out suitable exercises.
- * When writing mechanisms for organic reactions students need to practice the correct method along with correct usage of symbols.
- * When explaining concepts in chemistry, suitable learning teaching methods and equipment should be used to facilities understanding.
- * In every possible instance of the learning teaching process, the concepts need to be related to the day to day living in a practical perspective.
- * A greater attention of students should be drawn to the sections newly introduced to the syllabus.
- * Exercises should be done following the common method of solving problems correctly. First the problem should be studied and the shortest route to be taken to get the correct answer should be stressed.
- * Since the achievement level of the last units of the syllabus is relatively low, the learning teaching process should be geared to draw more attention towards them.
- * Modern technology should be used in the teaching-learning process and accessing of internet gives the chance for proper studying of the subject matter related to practical chemistry.
- * In the projects done under the school based assessments, it is required to pay attention on the things related to the subject .



LOL.Ik
Learn Ordinary Level

විභාග ඉලක්ක පහසුවෙන් ජයගන්න පසුගිය විභාග ප්‍රශ්න පත්‍ර



• Past Papers • Model Papers • Resource Books
for G.C.E O/L and A/L Exams



විභාග ඉලක්ක ජයගන්න
Knowledge Bank



Master Guide

WWW.LOL.LK



CASH ON DELIVERY

Whatsapp contact
+94 71 777 4440

Website
www.lol.lk

 **Order via WhatsApp**

071 777 4440