

ශ්‍රී ලංකා විභාග දෙපාර්තමේන්තුව ශ්‍රී ලංකා විභාග දෙපාර්තමේන්තුව ශ්‍රී ලංකා විභාග දෙපාර්තමේන්තුව ශ්‍රී ලංකා විභාග දෙපාර්තමේන්තුව ශ්‍රී ලංකා විභාග දෙපාර්තමේන්තුව
 இலங்கைப் பரீட்சைத் திணைக்களம் இலங்கைப் பரීட்சைத் திணைக்களம் இலங்கைப் பரීட்சைத் திணைக்களம் இலங்கைப் பரීட்சைத் திணைக்களம் இலங்கைப் பரීட்சைத் திணைக்களம்
 Department of Examinations, Sri Lanka Department of Examinations, Sri Lanka Department of Examinations, Sri Lanka Department of Examinations, Sri Lanka Department of Examinations, Sri Lanka
 ශ්‍රී ලංකා විභාග දෙපාර්තමේන්තුව ශ්‍රී ලංකා විභාග දෙපාර්තමේන්තුව ශ්‍රී ලංකා විභාග දෙපාර්තමේන්තුව ශ්‍රී ලංකා විභාග දෙපාර්තමේන්තුව ශ්‍රී ලංකා විභාග දෙපාර්තමේන්තුව
 இலங்கைப் பரීட்சைத் திணைக்களம் இலங்கைப் பரීட்சைத் திணைக்களம் இலங்கைப் பரීட்சைத் திணைக்களம் இலங்கைப் பரīட்சைத் திணைக்களம் இலங்கைப் பரīட்சைத் திணைக்களம்
 Department of Examinations, Sri Lanka Department of Examinations, Sri Lanka Department of Examinations, Sri Lanka Department of Examinations, Sri Lanka Department of Examinations, Sri Lanka

84 E I, II

අධ්‍යයන පොදු සහතික පත්‍ර (සාමාන්‍ය පෙළ) විභාගය, 2018 දෙසැම්බර්
 கல்விப் பொதுத் தராதரப் பத்திர (சாதாரண தர)ப் பரீட்சை, 2018 டிசெம்பர்
 General Certificate of Education (Ord. Level) Examination, December 2018

ශ්‍රී ලේඛ කලා I, II
 நுண்கலை I, II
 Arts and Crafts I, II

07.12.2018 / 0830 - 1140

පැය තුනයි
 மூன்று மணித்தியாலம்
 Three hours

අමතර කියවීමේ කාලය - මිනිත්තු 10 යි
 மேலதிக வாசிப்பு நேரம் - 10 நிமிடங்கள்
 Additional Reading Time - 10 minutes

Use **additional reading time** to go through the question paper, select the questions and decide on the questions that you give priority in answering.

Arts and Crafts I

Note :

- Answer *all* questions.
- In each of the questions 1 to 40, pick one of the alternatives (1), (2), (3), (4) which is *correct or most appropriate*.
- Mark a cross (X) on the number corresponding to your choice in the answer sheet provided.
- Further instructions are given on the back of the answer sheet. Follow them carefully.

- Very attractive creations that help earn foreign exchange are made by using the art of 'bobbin lace' (beeralu lace) which is famous as a folk art. The area where the art of 'bobbin lace' is more popular is
 - Western Province.
 - Southern Province.
 - Uva Province.
 - North-Western Province.
- Which of the following sets of angles can be constructed by using the pair of set squares?
 - 10°, 20°, 30°
 - 25°, 50°, 75°
 - 30°, 45°, 60°
 - 50°, 70°, 90°
- Different types of lines are used in drawing of Geometrical constructions. The type of lines shown in the diagram is used to
 - indicate the intersection points of a construction.
 - show the hidden lines of a construction.
 - indicate the middle axis or symmetry of a construction.
 - show the holes within a construction.
- The angle PQR of the triangle shown in the diagram is
 - an acute angle.
 - a right angle.
 - an obtuse angle.
 - a reflex angle.
- Consider the following statements.
 - Opposite sides are equal and parallel.
 - Opposite angles are equal.
 - Diagonals are not equal in length.
 - Diagonals bisect each other but they are not perpendicular to each other.
 What is the quadrilateral that includes all the above features?
 - Square
 - Rectangle
 - Rhombus
 - Rhomboid

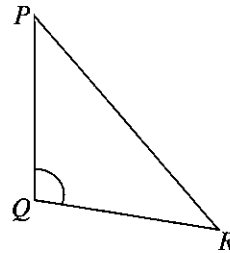

6. What is the magnitude of an angle that can be obtained by bisecting an interior angle of a regular hexagon?

- (1) 60° (2) 90°
 (3) 120° (4) 140°

7. "The locus of a moving point equidistant to a certain fixed point on a plane" is called
 (1) a circle. (2) an ellipse. (3) a closed diagram. (4) a curved surface.

8. Select the choice indicated by the letters A, B, C and D in the circle shown in the diagram correctly.

- (1) A - Centre, B - Segment, C - Quadran, D - Radius
 (2) A - Centre, B - Quadran, C - Radius, D - Segment
 (3) A - Centre, B - Quadran, C - Segment, D - Radius
 (4) A - Centre, B - Radius, C - Segment, D - Quadran

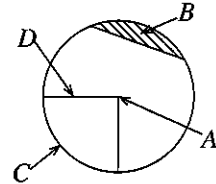

9. When an ellipse is constructed by using concentric circles, the components of the ellipse that is equal to the diameter of the smaller circle?

- (1) length of the major axis. (2) length of the minor axis.
 (3) distance between two foci. (4) distance to the minor axis from the focus.

10. When a development of a cylinder is constructed, the length of the development line drawn is equal to

- (1) the radius of the curved surface. (2) the circumference of the cylinder.
 (3) the height of the cylinder. (4) the diameter of the curved surface.

11. In dyeing, secondary colour is made by using two basic colours. Of the following options, which one gives two secondary colours?

- (1) Blue, Yellow (2) Orange, Yellow (3) White, Red (4) Green, Orange

12. In textile decoration, various methods like painting, dyeing and printing etc are used. Out of these, printing can be identified as

- (1) applying paint to spread throughout the textile material.
 (2) applying paint on a selected area with an external instrument.
 (3) stamping on the textile material using a prepared block.
 (4) applying colours on the textile material with a paint brush.

13. Given below are several post-treatment methods that are followed to fix the paint after textile decoration.

- A - washing after steaming
 B - drying in hot sunlight
 C - drying in shade for 72 hours after printing
 D - boiling in low temperature
 E - Ironing under high temperature

Out of these, which option includes post-treatment methods followed in fixing the paint in cloths printed or painted?

- (1) A, B, C and D. (2) A, B, D and E.
 (3) A, C, D and E. (4) B, C, D and E.

14. Given below is the order of a textile decorating method.

- A - pre-treatment of the textile material
 B - cutting of any shape from a printed piece of cloth
 C - ironing the piece of cloth that was cut placing it on a special paper
 D - cutting the piece of cloth off the paper and removing the piece of paper not pasted
 E - put it on the required place of the textile material and is ironed again

What is the textile decorating method that this process is followed?

- (1) Heat N' bond (2) Screen printing
 (3) Stencil printing (4) Block printing

15. Designs are embossed by tying a piece of cloth in different ways and creating bonds as a textile decoration in
 (1) light-sensitive method. (2) wet dyeing.
 (3) tie and dye process. (4) batik designing process.
16. Various dyes are used in different methods for decorations. For paints used in screen printing,
 (1) a thickening agent is used to avoid flowing of paint.
 (2) liquid paint is used to make it easy for increasing and decreasing colour.
 (3) preservative agents are added to make the paint durable.
 (4) use paints related to local plant extracts to get brightness of colours.
17. Cloth material have to be subjected to pre-treatment methods before textile decoration to make them absorb the paint well. The most suitable pre-treatment method for cotton related textile is
 (1) steaming, carbonizing and bleaching.
 (2) starch removing, rust removing and bleaching.
 (3) vaporization, reduction and bleaching.
 (4) removal of gum, carbonizing and bleaching.
18. Various kind of yarn are used for weaving. The type of cloth that gives large flames of yellow colour and a smell similar to paper burning, when subjected to the fire-test for identifying a woven piece of cloth is
 (1) linen. (2) silk. (3) cotton. (4) wool.
19. At present, cloths woven with artificial silk yarn are more popular than cloths woven with natural silk yarn. Several statements on that are given below.
 A - Convenient for washing and drying.
 B - Ability to buy in any colour from any shop.
 C - Convenience of easy access and low price.
 D - having bright colours and low in absorbing quality.
 Out of the above statements, those that give reasons for cloths done with artificial silk yarns to be more popular are
 (1) A and B only. (2) A and C only.
 (3) B and C only. (4) C and D only.
20. In textile technology, yarn is produced using different kinds of fibre. Fibre for natural silk is obtained from
 (1) cocoon of the silk worm. (2) fibre of flax plant.
 (3) wool of Kashmir goat. (4) asbestos deposits.
21. Select, out of these weaving pattern, the weave pattern that is woven with close bindings and used commonly.

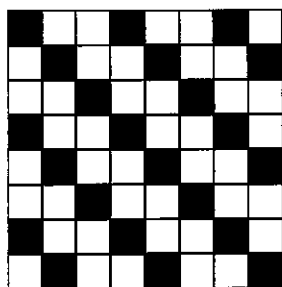

(1)

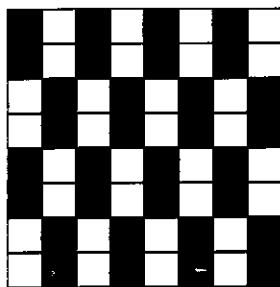

(2)

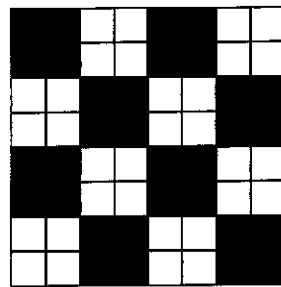

(3)

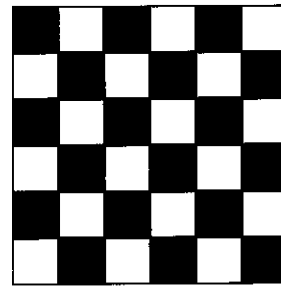

(4)

22. Twill weave patterns have been named according to the way twill line moves. Out of the following weave patterns, select the regular twill weave that is specially used to weave trouser material.

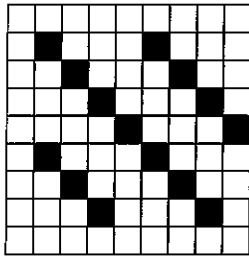

(1)

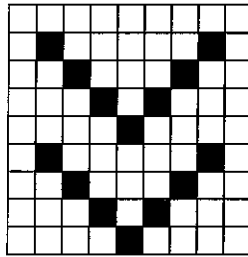

(2)

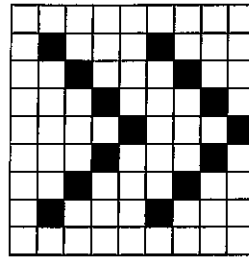

(3)

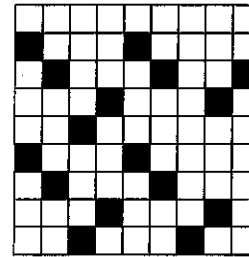

(4)

23. Warping board is used to elongate a small warp with reduced length and width. The instrument used to elongate a warp with increased length and width is

- (1) heck. (2) warp roller. (3) swift. (4) winding machine.

24. Tablet cards are used to weave beautiful ribbons easily. How many threads can be used in a tablet card?

- (1) 2 (2) 3 (3) 4 (4) 6

25. Weaving is done by sending weft-picks through ends. To fix weft-picks, what should be inserted into the shuffle is

- (1) pirn with yarn. (2) bobbin with yarn.
(3) healds with yarn. (4) comb with yarn.

26. Given below are several components that are fixed in looms. Select the option that has named them accurately.

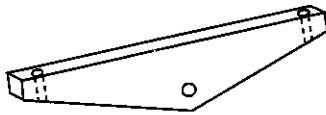

A



B

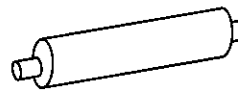

C

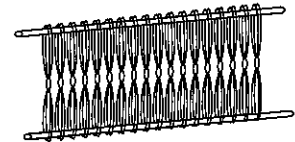

D

- (1) A - Lever, B - Warp beam, C - Comb, D - Healds
(2) A - Lever, B - Comb, C - Warp beam, D - Healds
(3) A - Warp beam, B - Healds, C - Lever, D - Comb
(4) A - Warp beam, B - Comb, C - Lever, D - Healds

27. The weight of a bale of yarns of the metric number 18^s is 5kg. How many skeins are there in the bale?

- (1) 120 (2) 100 (3) 90 (4) 80

28. The number of yarns in a serviette warp that is 50 m long 20 cm wide and that have 30 ends per centimetre is

- (1) $30 \times 50 = 1500$. (2) $50 \times 20 = 1000$.
(3) $30 \times 20 = 600$. (4) $20 \times 20 = 400$.

29. The number of two-ply skeins needed to weave table mat is 40. If one kilo gram includes 40 skeins, what is the number of the yarn?

- (1) 20^s (2) $\frac{2}{20^s}$ (3) $\frac{2}{40^s}$ (4) $\frac{2}{80^s}$

30. To weave a table cloth, a weave method with two ends and one pick was used. Select that weave method out of the following.

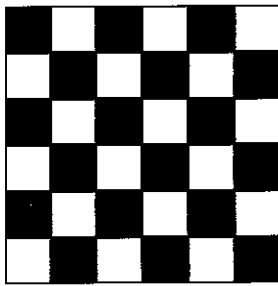

(1)

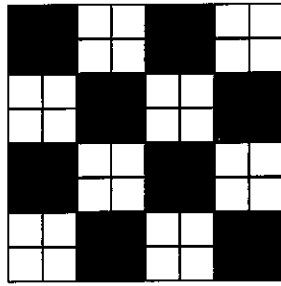

(2)

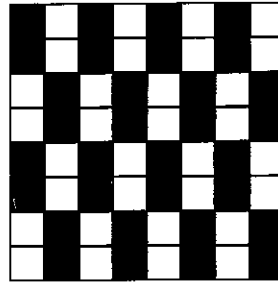

(3)

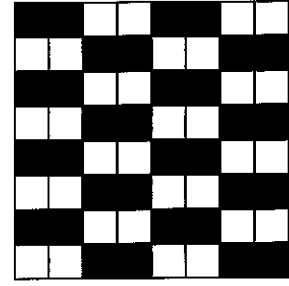

(4)

31. The type of clay used in manufacturing tiles and bricks for building construction is
 (1) kaolinite. (2) red clay. (3) fire clay. (4) clay consisting mica.

32. In clay formation, the clay that is deposited in the place where mother rock decayed is called primary clay. This contains only the basic compounds of mother rock and they are

- (1) organic matter, iron and magnesium.
- (2) zircon, kaolinite and mica.
- (3) aluminium oxide, silicon dioxide and water.
- (4) montmorillonite, silicon oxide and water.

33. As the shape of a clayware cannot be maintained with clay having high plasticity, the matter that should be added to keep the required standard is

- (1) kaolin with low percentage of iron.
- (2) ball clay with high collodial nature.
- (3) ball clay with high level of organic matter.
- (4) fire clay with high percentage of silica.

34. In large-scale factories, high quality clayware are manufactured according to a special standard. The percentage of non-sticky and sticky raw-material used is

- (1) 80% and 20% respectively. (2) 65% and 35% respectively.
- (3) 55% and 45% respectively. (4) 40% and 60% respectively.

35. Given below are several clayware produced using different techniques. Select the option that gives correctly, the techniques that have been used to make them.

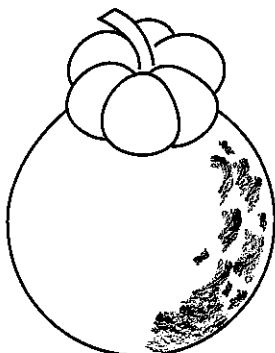

A

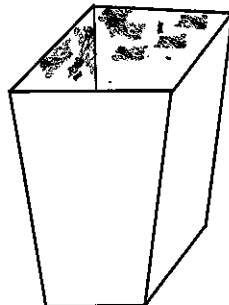

B



C

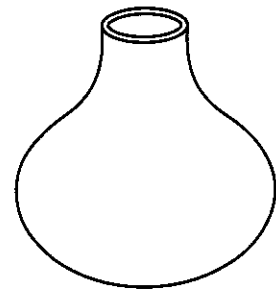

D

- (1) A - clay slab method, B - coiling methods, C - finger-tip method, D - potter's wheel method
- (2) A - potter's wheel method, B - coiling method, C - clay slab method, D - finger-tip method
- (3) A - coiling method, B - clay slab method, C - finger-tip method, D - potter's wheel method
- (4) A - finger-tip matter, B - clay slab method, C - coiling methods, D - potter's wheel method

36. In manufacturing of clayware, the clayware should be fired within a suitable temperature range. Within which of the following ranges of temperature should porcelainware fired?

- (1) 850°C - 900°C
- (2) 1000°C - 1200°C
- (3) 1250°C - 1350°C
- (4) 1500°C - 2100°C

37. The correct method that should be followed in preparing plaster of Paris mixture for making moulds is

- (1) to put the necessary amount of water into the vessel and drop plaster of Paris powder in small amounts.
- (2) to put necessary amount of plaster of Paris powder into the vessel at once and sprinkle water in small amounts.
- (3) to prepare by adding water and plaster of Paris powder alternatively.
- (4) to put the necessary amount of water into the vessel and drop the full amount of plaster of Paris powder at once.

38. To decorate clayware following techniques are used.

- A - Carving
- B - Marble pattern method
- C - Glazing
- D - Applying decoupage patterns

Out of the above, the decorative methods that can be used to decorate a clayware that has been fired to the state of bisque-firing are

- (1) A, B and C.
- (2) A, C and D.
- (3) B, C and D.
- (4) A, B and D.

39. Given here is a clayware made using a mould. To make this

- (1) a mould with two parts has to be used.
- (2) a simple mould with a single part has to be used.
- (3) a complete mould with several parts has to be used.
- (4) a special mould with four parts has to be used.

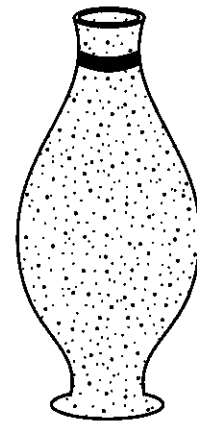

40. The following figure shows a local kiln. Which option has named the parts A, B, C and D accurately?

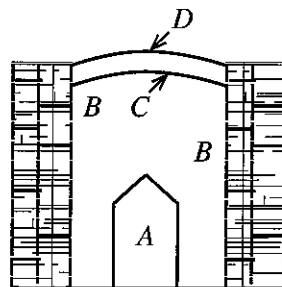

- (1) A - place clayware are piled, B - kiln, C - layer of clay, D - layer of straw
- (2) A - layer of clay, B - kiln, C - place clayware are piled, D - layer of straw
- (3) A - kiln, B - place clayware are piled, C - layer of clay, D - layer of straw
- (4) A - kiln, B - place clayware are piled, C - layer of straw, D - layer of clay

* *

ශ්‍රී ලංකා විභාග දෙපාර්තමේන්තුව ශ්‍රී ලංකා විභාග දෙපාර්තමේන්තුව ශ්‍රී ලංකා විභාග දෙපාර්තමේන්තුව ශ්‍රී ලංකා විභාග දෙපාර්තමේන්තුව ශ්‍රී ලංකා විභාග දෙපාර්තමේන්තුව
 இலங்கைப் பரீட்சைத் திணைக்களம் இலங்கைப் பரීட்சைத் திணைக்களம் இலங்கைப் பரීட்சைத் திணைக்களம் இலங்கைப் பரීட்சைத் திணைக்களம் இலங்கைப் பரීட்சைத் திணைக்களம்
 Department of Examinations, Sri Lanka Department of Examinations, Sri Lanka Department of Examinations, Sri Lanka Department of Examinations, Sri Lanka Department of Examinations, Sri Lanka
 ශ්‍රී ලංකා විභාග දෙපාර්තමේන්තුව ශ්‍රී ලංකා විභාග දෙපාර්තමේන්තුව ශ්‍රී ලංකා විභාග දෙපාර්තමේන්තුව ශ්‍රී ලංකා විභාග දෙපාර්තමේන්තුව ශ්‍රී ලංකා විභාග දෙපාර්තමේන්තුව
 இலங்கைப் பரීட்சைத் திணைக்களம் இலங்கைப் பரීட்சைத் திணைக்களம் இலங்கைப் பரීட்சைத் திணைக்களம் இலங்கைப் பரීட்சைத் திணைக்களம் இலங்கைப் பரීட்சைத் திணைக்களம்
 Department of Examinations, Sri Lanka Department of Examinations, Sri Lanka Department of Examinations, Sri Lanka Department of Examinations, Sri Lanka Department of Examinations, Sri Lanka

84 E I, II

අධ්‍යයන පොදු සහතික පත්‍ර (සාමාන්‍ය පෙළ) විභාගය, 2018 දෙසැම්බර්
 கல்விப் பொதுத் தராதரப் பத்திர (சாதாரண தர)ப் பரீட்சை, 2018 டிசெம்பர்
 General Certificate of Education (Ord. Level) Examination, December 2018

ශිල්ප කලා	I, II
நுண்கலை	I, II
Arts and Crafts	I, II

Arts and Crafts II

* Answer five questions, including question one and four other questions.

1. The Small Industries Development Department intends to hold an exhibition of handcrafts and an awarding of colours to value the contribution made by craftsmen to popularize the cultural heritage of Sri Lanka among local and foreign tourists. This exhibition is expected to be held in Kandy municipal Council premises and the students of Arts and Crafts in Kandy district have been given an opportunity to participate in the exhibition.
 - (i) Create a poster to make people aware of this exhibition and colours awarding ceremony.
 - (ii) Prepare a creation to decorate the front page of the invitation that is to be sent to the invitees.
 - (iii) An official emblem is needed to identify the craftsmen participating in the exhibition. Creates a suitable emblem with a thematic phrase.
 - (iv) Name **four** interior decorations made of local raw-materials which can be exhibited and put on sale.
 - (v) It is expected to use creations made of low-cost natural resources for the ornaments of the dancers who present the welcome dance. State **two** raw-materials suitable for that.
 - (vi) The front entrance has been decorated with a large motif of twin swans woven with tender coconut leaves using plain weave pattern. Draw **two** units of plain weave pattern.
 - (vii) Draw a development of a packing regular hexagon in shape for packing sweetmeats given to the invitees.
 - (viii) Mention **two** traditional decorative methods in creating clayware that are suitable to decorate the clayware that have been subjected to first firing.
 - (ix) Draw a model of a trophy to be awarded to those who have won colours.
 - (x) It is expected to weave a colourful warp to be used in decorations. What should be the length of the warping to weave 100 m of cloths, taking into consideration the shrinkage is 10%?
2. In creative technology, it is essential to draw design plans for creating a standard article. For this geometric and mechanical drawing is used.
 - (i) Divide a line of 9 cm to 7 equal parts.
 - (ii) Create using any method, a regular pentagon which is needed to make a pentagon ball that falls under light toys. Use measurements of your choice.
 - (iii) Draw the development of a cuboid 6 cm long, 4 cm wide and 3 cm high.

3. Components are made for various purposes using methods different from each other in diverse medium.

- (i) How is the wax mixture prepared in Batik decorations, when only crack designs are needed?
- (ii) Present the block that is suitable for sewing a small handbag and state briefly how it is formed together to make a handbag. Name **two** patterns of sewing that can be used to decorate it.
- (iii) Make a brief introduction on the fly shuttle loom which is a special machine among handlooms.

4. It is expected to weave a serviette warp with the help of a handloom. The rough sketch and the description of the warp of yarn prepared for this is given below.

- * Length of the warp - 100 meters
- * Width of the warp - 60 centimetres
- * Number of warp ends per centimetres - 60
- * Count of yarn - $\frac{2}{60^s}$
- * Colour of the yarn - light green

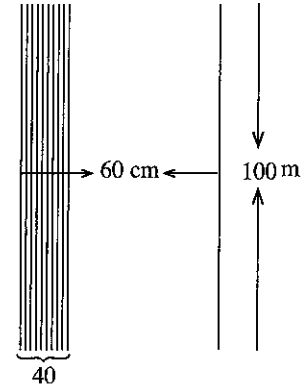

- (i) Name **two** twill weave patterns suitable for weaving serviettes.
- (ii) Show in a chart the overlaid threads of the above named twill weave patterns.
- (iii) Calculate the amount of $\frac{2}{60^s}$ yarn needed to weave the warp.

5. At present, decorative methods of textiles are changing rapidly. Modern decorative techniques have come to the fore over traditional techniques.

- (i) Home decoration methods that do not use sewing machine, other sewing methods and type of dyes have been introduced. Name **two** such decorative methods.
- (ii) Through screen printing, even delicate designs can be created. Explain briefly, how the design is taken to the screen through light-sensitive method.
- (iii) State **two** advantages of mould printing method that is used in textile printing and draw a suitable pattern for a mould and colour the parts that should be printed.

6. Various methods are used in producing clayware and different methods of decorating are also used. There are clayware for which first firing is sufficient and others done with different decorative methods such as glazing, colouring and decorating.

- (i) Name **four** kilns that are used for firing clayware.
- (ii) State **four** advantages of using a clayware polished with glazing mixture after first firing.
- (iii) State, in order, how a flower vase is built using clay coils.

7. Many people are interested in keeping the environment they live beautiful and create different components to do so.

- (i) State **two** fundamentals of horticulture.
- (ii) Name **two** techniques of sculpturing and explain one of them with examples.
- (iii) State, in order, how a wall profile is created using cement medium.



PAST PAPERS WIKI

ප්‍රශ්නපත්‍ර පොත්
ගෙදරටම ගෙන්වා ගන්න
ඔන්ලයින් ඕඩර් කරන්න

www.store.pastpapers.wiki

වෙත යන්න



ONLINE BOOK STORE

An evening of fun for young readers

