



වයඹ පළාත් අධ්‍යාපන දෙපාර්තමේන්තුව Provincial Department of Education - NWP

Third Term Test - Grade 09 - 2023
තෙවන වාර පරීක්ෂණය - 09 ශ්‍රේණිය - 2023

Mathematics

Time
2 hours 30 minutes

Name:-

Part I

- Answer all 20 questions on this paper itself.
- Correct answer for each question carries 2 marks.

01. Find the 5th term of the number pattern with general term $5n-1$

02. A vendor buys a bag for Rs. 2000 and sells it at a profit of 10%. Find the selling price of the bag

03. Find the value $(2^3)^0 + 1$

04. Solve the inequality $x - 1 > -1$ and represent the integral solutions on the number line given.

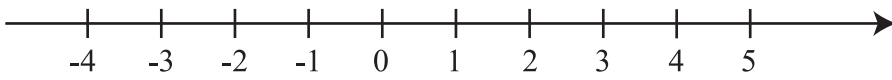

05. Make d the subject of the formula, $l = a + (n-1) d$

06. Find the magnitudes of the angles denoted by x and y in the diagram given below

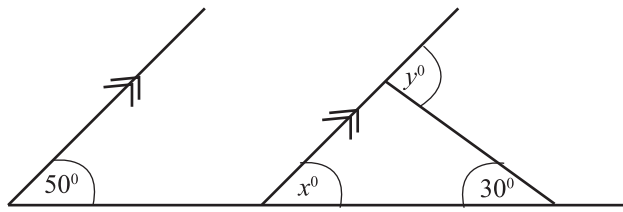

07. Factorize $a^2 + a - 6$

08. In the diagram given below,

$$\hat{AOC} = \hat{BOD}, \hat{AOD} = 150^\circ \text{ and } \hat{AOB} = 40^\circ$$

i. Find the value of \hat{COD}

ii. Find the value of \hat{BOC}

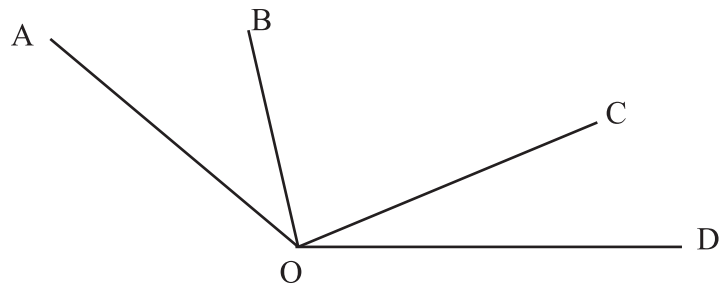

09. A cuboid shaped container has a square base of area 144 cm^2 . An amount of 2.16 l of water has been filled into this container. Find the height of the water in the container.

10. Convert 28_{ten} into a binary number

11. The value of an electric appliance available for sale in the duty free shop is 500 American dollars. How many Sri Lankan rupees should be paid to buy this appliance?
(1 American dollar = 328 Sri Lankan rupees)

12. Find the value of h in the parallelogram ABCD given below

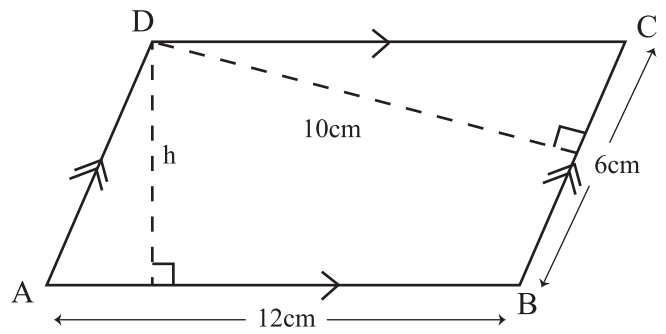

13. Mark the correct statements with "✓" and the incorrect statements with "✗"

- i. The order in which the keys need to be pressed in a calculator, to obtain the length of a side of a square with the area 9 cm^2 is,

→ → → → ()

- ii. $A = \{ \text{the digits of the number } 1640 \}$ This is a finite set ()

- iii. The graphs of the form $y = mx$ always passes through the point $(0,0)$ ()

14. Round off 43.75 to the nearest first decimal place.

15. Find the value of x°

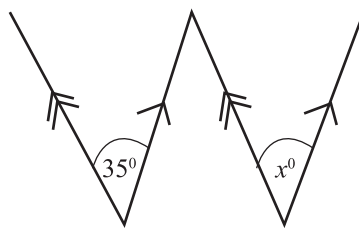

16. Simplify and express the answer in the simplest form.

$$\frac{1}{3} + \frac{1}{7} \div \frac{3}{7}$$

17. Find the value by using the knowledge of factors.

$$112^2 - 12^2$$

18. Find the value of $m^\circ + n^\circ$ in the figure given

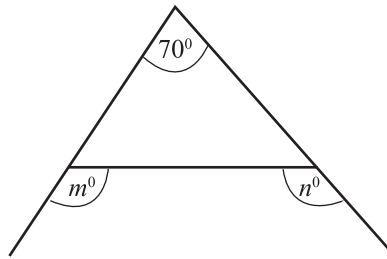

19. The length and breadth of the rectangle PQRS given in the figure are $(x - 2)$ units and $(x - 5)$ units respectively.

Write the area of the rectangle as a quadratic trinomial expression.

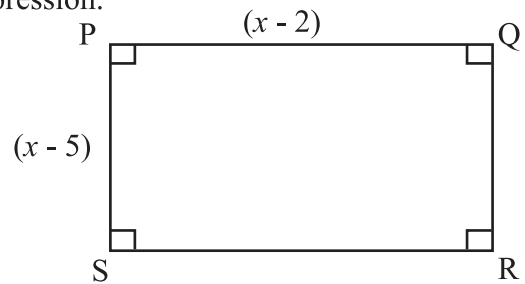

20. A grouped frequency distribution prepared by using the marks obtained by a group of students in grade 9 for mathematics, is given below

| class intervals | frequency |
|-----------------|-----------|
| 21 - 30 | 1 |
| 31 - 40 | 3 |
| 41 - 50 | 9 |
| 51 - 60 | 8 |
| 61 - 70 | 6 |

Find (i.) the modal class
(ii.) the median class
of this distribution



Third Term Test - Grade 09 - 2023
තෙවන වාර පරීක්ෂණය - 09 ශ්‍රේණිය - 2023

Mathematics

Name:-

Part II

- Answer the first question and 04 other questions.
- First question carries 16 marks and other questions carry 11 marks each

01. a) An activity you engaged in the classroom regarding the angles of polygons, is given below.

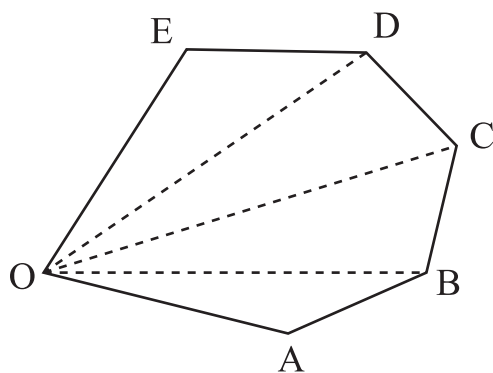

| Polygon | Number of sides | Name of the polygon | Number of triangles | Sum of the interior angles |
|---------|-----------------|---------------------|---------------------|----------------------------------|
| OAB | 3 | Triangle | 1 | $180^\circ \times 1 = 180^\circ$ |
| OABC | 4 | Quadrilateral | 2 | $180^\circ \times 2 = 360^\circ$ |
| OABCD | | | | |
| OABCDE | | | | |

- Complete the table using the figure given above (4 marks)
- According to the table, write down an expression for the sum of the interior angles of a polygon with 'n' number of sides (1 mark)
- The value of an exterior angle of a certain regular polygon is 30° . Find the number of sides of that polygon (2 marks)
- Find the magnitudes of the angles denoted by x° and y° in the polygon given below.

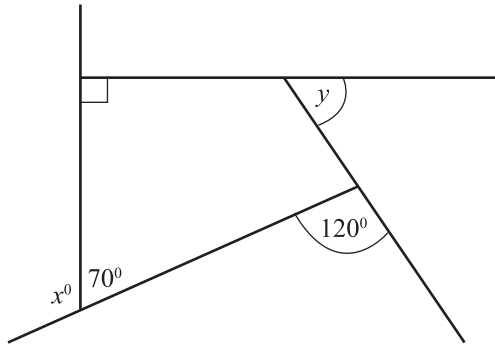

(2 marks)

b) Simplify and express the answer in the simplest form.

i. $\frac{a}{7} + \frac{6a}{7}$

(2 marks)

ii. $\frac{2x+3}{5} - \frac{x+1}{5}$

(2 marks)

c) Solve
$$\begin{aligned} 2m + n &= 4 \\ m + n &= 3 \end{aligned}$$

(3 marks)

02. a) Answer the following questions using the Venn diagrams given below

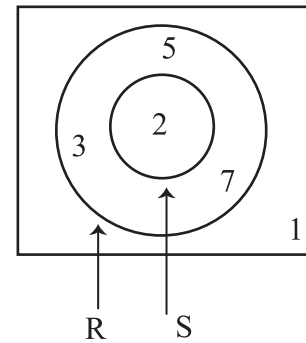
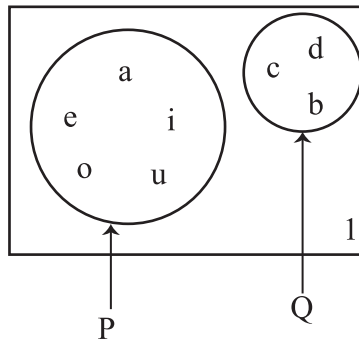
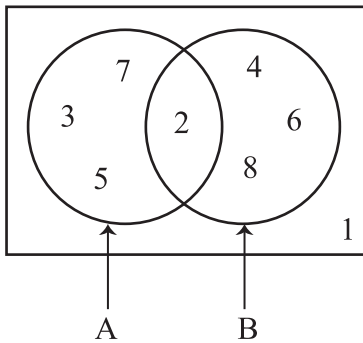

i. Name two disjoint sets (2 marks)

ii. Write the relationship between the two sets R and S in set notation (2 marks)

iii. Write each of the following sets in terms of its elements.

a) $A \cap B$ (1 marks)

b) $P \cup Q$ (1 marks)

c) $R \cap S$ (1 marks)

b) There are 5 identical cards numbered from 1 to 5 in a box. Consider the experiment of drawing a card at random from the box.

i. Write the sample space of the experiment (2 marks)

ii. Find the probability of drawing a card with a prime number (2 marks)

03. a) An incomplete table prepared to draw the graph of the function $y = 2x - 1$ is given below

| | | | | | |
|-----|----|-------|----|-------|---|
| x | -2 | -1 | 0 | 1 | 2 |
| y | -5 | | -1 | | 3 |

- i. Fill in the blanks in the table (2 Marks)
- ii. Draw the graph of the function $y = 2x - 1$ on a suitable cartesian plane (3 Marks)
- iii. Write down the gradient and the intercept of the above graph (2 Marks)

b) The gradient of the straight line $2x + Py = 3$ is 1.

- i. Find the value of P (2 Marks)
- ii. Write the equation of the straight line which is parallel to $2x + Py = 3$ and having the intercept -1. (2 Marks)

04. A boat travels 120km on a bearing of 040° from harbour A to reach the harbour B. Then it travels 160 km on a bearing of 130° from harbour B to reach the harbour C.

- i. Draw a rough sketch based on the above information (2 Marks)
- ii. Draw a scale diagram based on the sketch, using the scale of 1cm representing 20km (5 Marks)
- iii. Using the scale diagram, find the actual distance between A and C (2 Marks)
- iv. Describe the location of C with respect to A. (2 Marks)

05. An ungrouped frequency distribution prepared with the information about the number of units of electricity consumed by a certain school during a month is given below.

| | | | | | | | | |
|--|---|---|---|---|---|---|---|---|
| Number of units of electricity consumed during a day | 2 | 3 | 4 | 5 | 6 | 7 | 8 | 9 |
| Number of days | 4 | 3 | 5 | 7 | 2 | 4 | 3 | 2 |

- i. What is the range of the above data set? (2 Marks)
- ii. Find the mode of the above data set (2 Marks)
- iii. Find the mean number of units of electricity consumed per day during the period in which data was collected, to the nearest whole number (5 Marks)
- iv. If Rs. 25 per unit for the first 100 units of electricity consumed and Rs. 50 per unit for every unit above that is charged, while the fixed charges is Rs. 1500, calculate the electricity bill of the school for this month. (2 Marks)

06. Use only a straight edge with cm/mm scale and a pair of compass to do the following constructions. Show the construction lines very clearly.

- i. Construct the triangle ABC in which $AB = 7\text{cm}$, $\hat{ABC} = 90^\circ$ and $\hat{BAC} = 45^\circ$ (4 Marks)
- ii. Construct the locus of points equidistant to the lines AB and BC (2 Marks)
- iii. Construct the straight line segment CY such that $\hat{BAC} = \hat{ACY}$ and Y lies on the side opposite to B of the line AC (2 Marks)
- iv. Name the intersection point of the above locus and the straight line segment constructed in part (iii) as D (1 Mark)
- v. Complete to the quadrilateral ABCD (2 Marks)

07. a) A circular vegetable plot of radius 7m which is in a piece of land in the shape of a trapezium is shown in the figure given below.

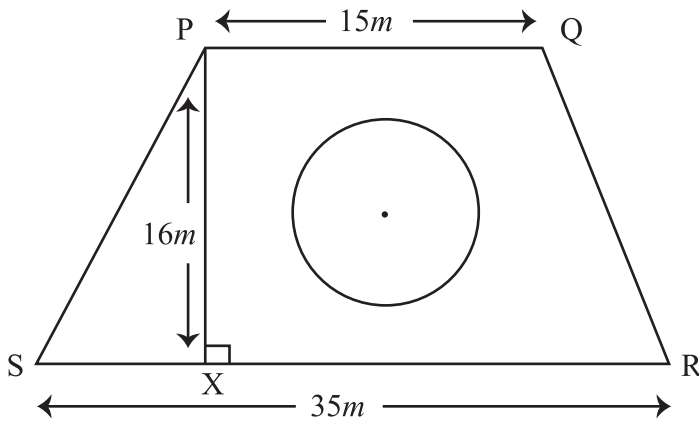

$PQ = 15\text{m}$, $SR = 35\text{m}$, and $PX = 16\text{m}$

- i. Find the circumference of the circular vegetable plot (2 Marks)
- ii. Find the area of the plot where vegetables are grown (2 Marks)
- iii. Find the area of a the piece of land (2 Marks)
- iv. It is decided to grow grass in the rest of the land except for the vegetable plot. The cost of growing grass in 1m^2 is Rs. 600. Find the cost of growing grass in this land (2 Marks)
- v. If $SX = 12\text{cm}$, calculate the length of the border PS (3 Marks)



(8) WWW.PastPapers.WiKi (8)



LOL.lk
BookStore

විභාග ඉලක්ක

පහසුවෙන් ජයගන්න

ඕනෑම පොතක් ඉක්මනින්
නිවසටම ගෙන්වා ගන්න



| කෙටි සටහන් | පසුගිය ප්‍රශ්න පත්‍ර | වැඩ පොත් | සඟරා | O/L ප්‍රශ්න පත්‍ර
| A/L ප්‍රශ්න පත්‍ර | අනුමාන ප්‍රශ්න පත්‍ර | අතිරේක කියවීම් පොත්
| School Book | ගුරු අත්පොත්



පෙර පාසලේ සිට උසස් පෙළ දක්වා සියලුම ප්‍රශ්න පත්‍ර,
කෙටි සටහන්, වැඩ පොත්, අතිරේක කියවීම් පොත්, සඟරා
සිංහල සහ ඉංග්‍රීසි මාධ්‍යයෙන් ගෙදරටම ගෙන්වා ගැනීමට

www.LOL.lk වෙබ් අඩවිය වෙත යන්න