

**Grade 11** **Third Term Test 2023(2024)** **32 E I**

Name : ..... **MATHEMATICS I** **Time : 02 Hours**

- Answer all the question on this paper itself.
- Indicate the relevant steps and the correct units when answering the question.
- Mark are awarded as follows. In part A, 02 marks for each question and in part B, 10 marks for each question.

**Part - A**

01. A person deposits an amount of Rs. 40 000 at an annual simple interest rate of 8%. How much interest does he get for this amount at the end of two years?

02. A Figure consisting of two sector shape iron wire frames. with radius of 7 cm. Find the minimum length of iron wire which is need to make this iron Frame.

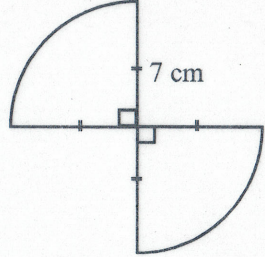

03.  $\log_5 x = 2$  i. Write down in index form  
ii. Find the value of 'x'

04. Simplify  $\frac{1}{x^2} - \frac{2}{3x^2}$

05. Find the value of  $\hat{PQS}$  according to the information given in the figure.

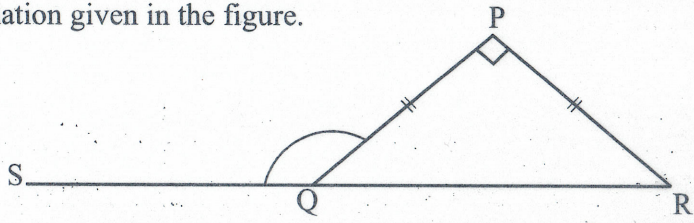

06. Solve  $\frac{1+x}{3} = 4$

07. Find the factors of,  
 $3x^2 - 5x - 8$

08. When cut and stretched the given hollow cylinder in the figure A, then receives a rectangular shape metal sheet as shown in the figure B. Find the radius of that cylinder.

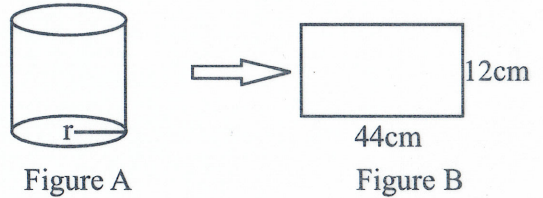

09. AB and CD are two vertical buildings 50 m away from each other. The angle of elevation of D is  $40^\circ$ , when observed from the top of the building AB and the angle of depression of C is  $35^\circ$  from A. Represent this information in the given figure.

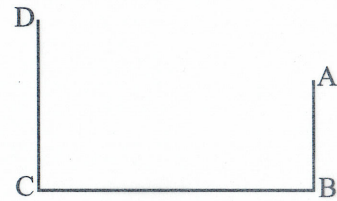

10. The following venn diagram has been drawn to represent the information of students who participated for a school trip. In the venn diagram shade the region that represent the girls who don't eat ice-cream

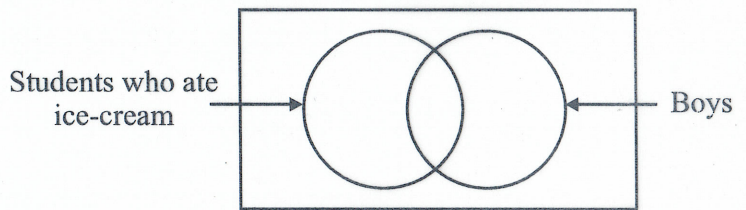

11. Solve.  
 $2x^2 - 98 = 0$

12. There are 20-30 number of identical colour cards and red colour cards in a same box. The probability of a card drawn at random from the box being red is  $\frac{5}{9}$ . How many cards in total are there in the box?

13. If  $AB = BD$  and  $AE = BC$ , Write the pair of triangles that are congruent from the triangles given in the figure and write the relevant case of congruency.

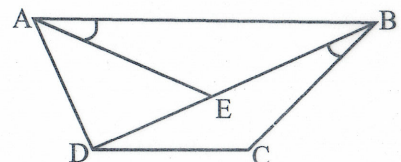

14. For the statements given below, mark a "✓" in front of the correct statements and a "×" in front of the incorrect statements.

- i. Diagonals are bisected as perpendicularly in a rhombus.
- ii. In a quadrilateral, if a pair of opposite sides is equal and parallel, it is a parallelogram
- iii. The opposite angles in a parallelogram are bisected by each diagonals

15. Find the least common multiple of terms of  $3x, 4x^2y, xy$

16. By using the below histogram, draw the relevant frequency polygon.

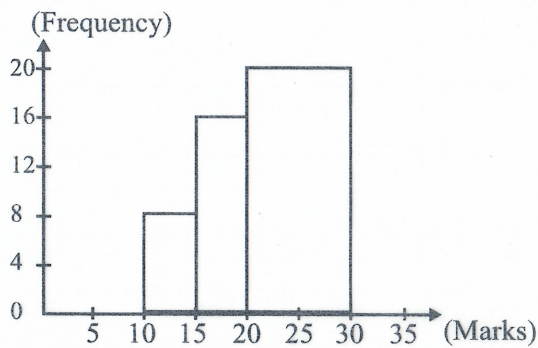

17. Find the value of 'x' according to the information given in the figure.

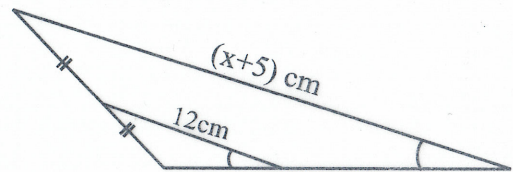

18. The circular cross section area of a cylindrical iron rod is  $15.4\text{cm}^2$  and its length is  $2\text{m}$ . Find the volume of that iron rod.

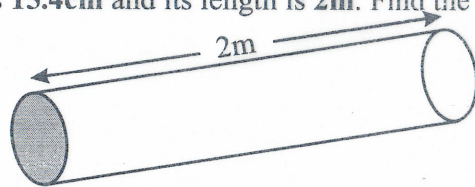

19. Solve the given inequality and represent the solutions on a number line.

$$2x - 1 \leq 5$$

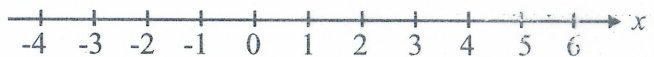

20. A, B and C points are on the below circle with centre 'O'. If  $\hat{AOC} = 78^\circ$ , Find the value of  $\hat{OCB}$

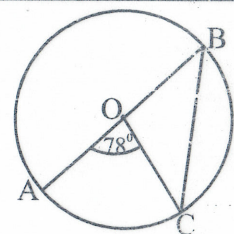

21. Below distance - time graph represents the motion of a certain vehical.  
According to the given data, find the speed of C to D.

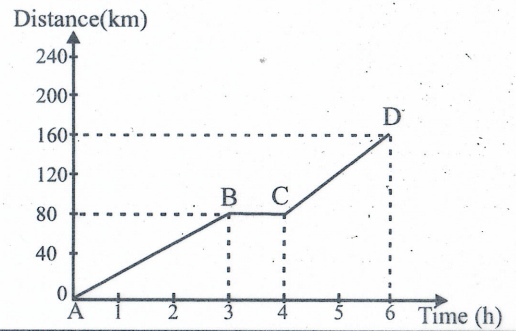

22. Find the value of 'x' according to the given data in the below figure.

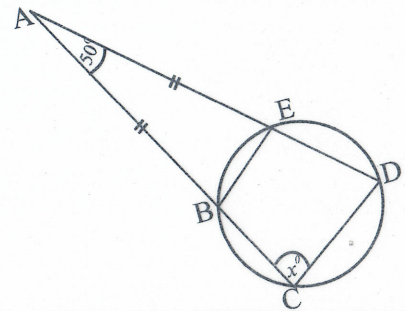

23. PQ is a locus moving 3m away from OA in the given figure. It is required to mark a point 'T' on the above locus PQ as equidistant from OA and OB. Sketch the correct position of 'T' in the below figure using the knowledge of loci.

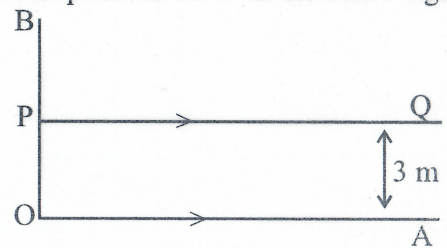

24. AB is a straight line in the given figure.

- Find the gradient of the straight line AB
- Write an equation of the straight line AB

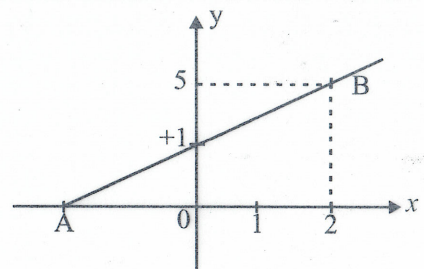

25. In the given figure,  $DC = 2 CP$  and  $\hat{CRQ} = 130^\circ$ .

BR and DP are two straight lines

- Find the length of  $\hat{AB}$
- Find the value of  $\hat{ADC}$

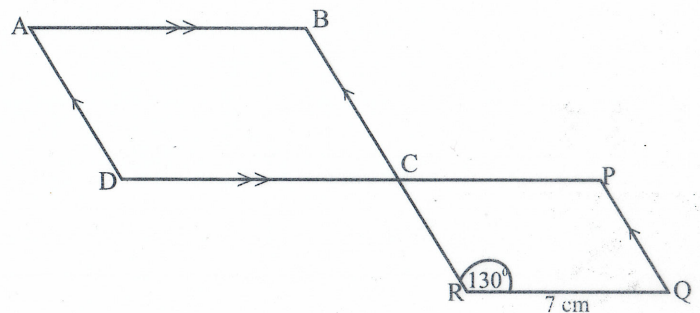

Alec

**PART - B**

- (01)  $\frac{1}{3}$  of a group of parents came to the school for sharamadana campaign, assigned to repair the play ground and  $\frac{3}{5}$  of remaining parents participated to fix the school fence. And all the other remaining parents were divided in to two equal groups. Form the two groups, one group repaired the grade 01 class room and the other group prepared flower beds.
- What is the fraction of the total number of parents who did not give contribution to repair the school play ground?
  - What is the fraction of the total number of the parents who contributed to fix the school fence?
  - If there were 6 parents in the group of repairing grade 01 class room, find the total number of parents who paticipated for this shramadana campaign.
  - It was estimated that 30 mandays were needed to repair the play ground. Find the number of days it takes for the group of parents who repaired the play ground to complete it.

- (02) Mr. Ranjith divided his rectangular shape land between his daughter and son as shown in the below figure. Daughter owned right angled triangler shape part and son owned trapezium shape part.

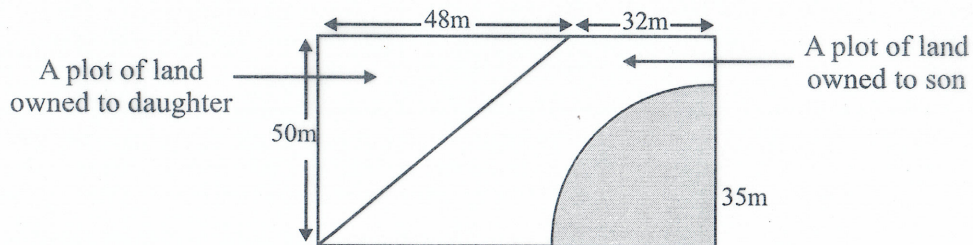

- Find the areas of the plots of land owned to daughter and son separately.
- Write the ratio between the areas of plots of land owned to daughter and son in simplest form.
- Vegetables are grown in the shaded part of sector with a radius of 35m as shown in the figure of the land owned to son. Find the perimeter of the shaded part.

iv. Both of daughter and son agreed to divide the plots of land owned to them again with the shape of two rectangles as the previous areas would not change. Draw the way of dividing the plots of land as rectangles in the above figure with the correct measurements.

(03)a. Mr. Ranjith owned 200 shares of company A. At the beginning of the financial year he sold 60% of his shares at the market price of 50 rupees per share and Mr. Ranjith bought a certain number of shares of company B at 60 rupees per share by investing the amount he received by selling the shares of company A

- i. Find how many number of shares Mr. Ranjith sold of company A.
- ii. Find how many number of shares Mr. Ranjith bought from company B .
- iii. At the end of the financial year, company 'A' paid 8 rupees per share and company 'B' paid 10 rupees per share as dividends. Find the total dividend income he recieved from the companies A and B at the end of a year.

b. Mr. Ranjith pays income tax for his annual income as follows.

Annual income (Rs.)	Income tax percentage
Initial 500 000	tax free
Next 500 000	4%
Next 500 000	8%

If his annual income is Rs. 1 150 000, Find the amount of income tax Mr. Ranjith has to pay.

(04)a. An incomplete cumulative frequency distribution showing the information about the number of units of water recieved by 60 households in one day according to a certain water supply system.

Number of units of water used by a household	Class intervals with boundaries	Frequency (No. of households)	Cumulative Frequency
8-12	7.5 - .....	4	.....
13-17	..... - 17.5	6	.....
18-22	17.5 - 22.5	15	25
23-27	22.5 - 27.5	15	40
28-32	27.5 - 32.5	10	50
33-37	32.5 - 37.5	7	57
38-34	37.5 - 42.5	.....	60

- i. Fill in the blanks in the above table.
- ii. Draw the cumulative frequency curve.
- iii. Find the interquartile range using the cumulative curve.

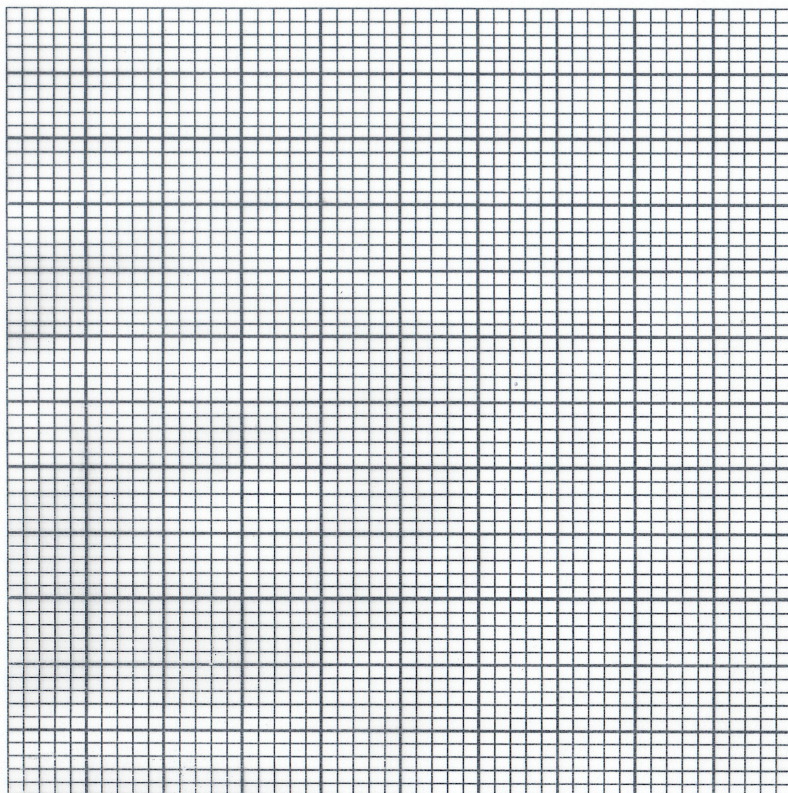

b. The pie chart given in the figure shows the usage of water units of these 60 households.

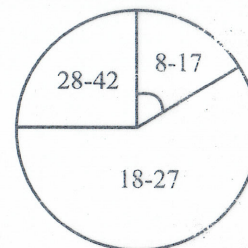

The 10 households are used 8-17 number of water units. Find the magnitude of the central angle of the sector that represent these 10 households.

- (05)a. It was revealed that a certain type of soft drinks contains toxic chemicals that are harmful to human health. The probability of getting an accurate result from the machine used to test it is  $\frac{15}{16}$ . Below incomplete tree diagram is showing whether or not a sample of the soft drinks tested with this machine has given an accurate result.
- i. Complete the tree diagram by indicating the relevant probabilities.

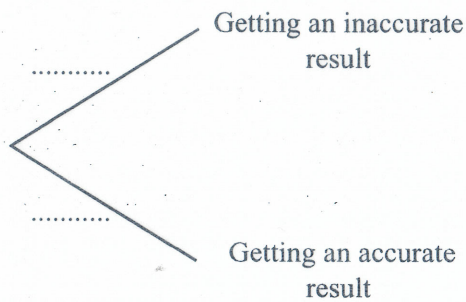

- When testing the sample of drinks from the above machine, If the machine gives an accurate result, it means that 80% of the sample contains the toxic chemical, and if the machine doesn't give an accurate result it is an equally likely whether the sample contains the toxic chemicals or not.
- ii. Extend the above tree diagram to indicate the sample of that soft drinks with toxic chemicals or without toxic chemicals.
- iii. By using the tree diagram find the probability of the randomly selected soft drink bottle from the above sample being a non-toxic one.

- b. In a box containing 5 small bottles of the above type of soft drink, one of which is 100 ml. 4 small bottles contain toxic chemicals and the remaining bottle doesn't contain toxic chemicals.

An inspection officer will randomly take a bottle from this box and check whether it is toxic or non-toxic and without replacing it, again he randomly takes another bottle and check it. ( Consider,  $P_1, P_2, P_3, P_4$  as bottles with the toxic chemicals and  $N_1$  as a bottle without toxic chemicals)

- i. Mark the sample space relevant to the above experiment in the given grid using the symbols.

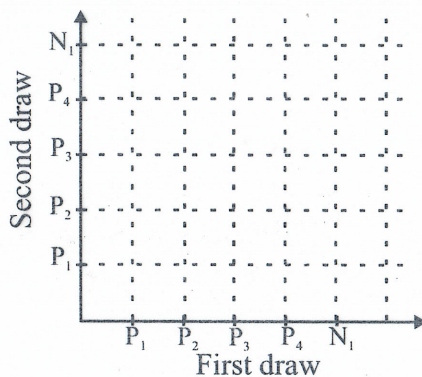

- ii. In the grid encircle the event of getting both bottles with toxic chemicals and without toxic chemicals and find its probability.



Dilhani

වයඹ පළාත් අධ්‍යාපන දෙපාර්තමේන්තුව වැයගිවල් ආරක්ෂා කළ යුතු වස්තුවකි. Department of Provincial Education - NWP  
වයඹ පළාත් අධ්‍යාපන දෙපාර්තමේන්තුව වැයගිවල් ආරක්ෂා කළ යුතු වස්තුවකි. Department of Provincial Education - NWP  
වයඹ පළාත් අධ්‍යාපන දෙපාර්තමේන්තුව වැයගිවල් ආරක්ෂා කළ යුතු වස්තුවකි. Department of Provincial Education - NWP  
වයඹ පළාත් අධ්‍යාපන දෙපාර්තමේන්තුව වැයගිවල් ආරක්ෂා කළ යුතු වස්තුවකි. Department of Provincial Education - NWP  
වයඹ පළාත් අධ්‍යාපන දෙපාර්තමේන්තුව වැයගිවල් ආරක්ෂා කළ යුතු වස්තුවකි. Department of Provincial Education - NWP

Grade 11

Third Term Test 2023(2024)

32 E II

Name : .....

MATHEMATICS II

Time : 03 Hours  
Additional Reading Time : 10 minutes

Instructions :-

- Answer ten questions selecting five questions from part A and five questions from part B
- Write the relevant steps and the correct units in answering the questions.
- Each question carries 10 marks
- The volume of a right circular cylinder of base radius r and height h is  $\pi r^2 h$
- The volume of a sphere of radius r is  $\frac{4}{3} \pi r^3$
- Use additional reading time to go through the question paper, select the questions and decide on the questions that you give priority to in answering.

Part - A

(01) An incomplete table of y values corresponding to several values of the quadratic function  $y = 3 - (x-1)^2$  is given below

X	-2	-1	0	1	2	3	4
Y	-6	-1	2	.....	2	-1	-6

- Find the value of y when  $x = 1$
  - Using the standard system of axes and a suitable scale, draw the graph of the given quadratic function on the provided graph paper, according to the above table.
- Using the graph that you drew
    - Write the interval of values of x on which the function increases within the interval  $-1 < y < 3$
    - By writing the positive root of the equation  $3 - (x-1)^2 = 0$ , Find the value for  $\sqrt{3}$  to the nearest first decimal place.
    - For the graph that is obtained by translating the above graph downwards by one unit on the Co - ordinate plane without changing the shape of the graph, the quadratic function in the form  $y = b - (x+a)^2$  is obtained. Find the value of a and b.

(02) A frequency distribution containing information on runs scored in 30 cricket matches, played by Suneth during the first few months of the year, is shown in the table below  
[ Here 0-15 means  $0 \leq x < 15$  ]

Number of runs scored by a match [ Class Interval ]	Number of cricket matches
0-15	1
15-30	3
30-45	5
45-60	11
60-75	5
75-90	4
90-105	1

- i. Suneth hopes to participate 35 cricket matches at the end of this year. Using the given data in the table and by taking a suitable assumed mean or otherwise, find the mean runs scored by Suneth to the nearest whole number. Hence calculate the total number of runs can be scored by Suneth at the end of the whole year.
- ii. If Suneth has scored highest runs from each and every match that he has already participated, show that the total runs he has already scored is less than the number of runs scored at the end of the whole year by playing all the 35 matches.

(03) If Mr. Jayasinghe takes a loan of 120 000 from a certain financial institute at a compound interest rate of 10% per year. Calculate the total interest required to pay the entire loan in two years. Then Mr. Jayasinghe has bought a sofa set priced of Rs. 200 000 by using the entire loan and paying the rest in 20 equal monthly installment. If an annual interest rate of 15% is charged on the loan for the sofa set where the interest is calculated on the reducing balance, find the total interest that has to be paid for the sofa set and show that the sum of the interest paid for the sofa set and the interest for the loan taken from the financial institute for 2 years not exceeding Rs. 36 000/=

- (04) a. If  $(2, -3) \begin{pmatrix} 3 & 0 \\ 1 & 2 \end{pmatrix} = (a, b)$ , Find the value of a and b
- b. Achala and Sanjana has a certain amount of money. If twice the amount of money that Sanjana has is added to the amount of money Achala has is Rs. 1150. If the twice the amount of money Achala has is added to the amount of money Sanjana has is Re. 1400.
- i. Taking the amount of money Achala has as Rs. x and the amount of money Sanjana has as Rs. y construct a pair of simultaneous equation containing x and y. By solving the pair of simultaneous equations, find the amount of money with Achala and Sanjana separately.
  - ii. If the total amount of money with both Achala and Sanjana is spent to by a pen and a book which is four times the value of a pen, find the price of the pen.

(05) ABCD is a rectangular shaped metal lamina. A triangular shaped part where  $AB=BF=x$  units is removed from the lamina and the remaining portion is shaded as given in the figure. If the area of the remaining portion is 30 square units and  $FC=6$  units then show that x satisfies the quadratic equation  $x^2 + 12x - 60 = 0$

Using the method of completing the square or any other method, solve the above equation and show that  $AB < \frac{1}{2} BC$  (Take  $\sqrt{6} = 2.44$ )

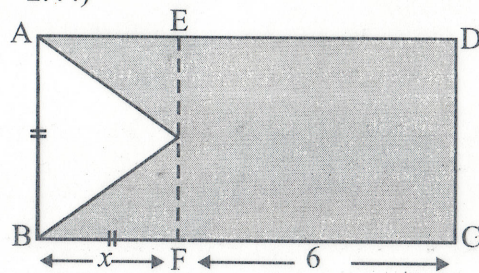

- (06) The diagram shows, a vertical tele-communication tower on the horizontal ground A and a transmission equipment of the company P is placed on the point B of the tower. the angle of elevation of the point B where the transmission equipment of the company P is situated, as seen from the point C which is 24m from the point A is  $42^\circ$ . (Neglect the height of the observer)
- i. Copy the diagram on to your answer script and mark the above data.
  - ii. Using the trigonometric table, calculate the height up to the place B where the transmission equipment of the company P is placed.

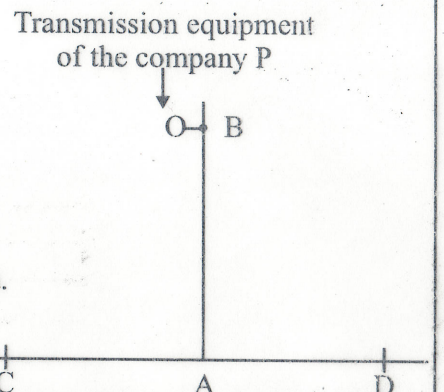

- iii. A metal wire of length 30m is fixed to the certain point Q of the tower AB to keep it in a vertical position, and the other end is fixed to the point D which is 24m from the point A. Find the angel between the metal wire and the horizontal ground.  
State with reason whether the transmission equipment of the company Q is located above or below the transmission equipment of the company P of the telecommunication tower.

### Part - B

- (07) The first three instances of a pattern constructed using the pieces of metal wires with equal lengths and iron nails are shown in the following diagram.

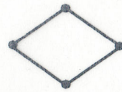

First pattern



Second pattern



Third pattern

- Write down separately the number of pieces of metal wires and number of iron nails which are used to construct first, second and third patterns respectively.
  - If the first three terms of an arithmetic progression can be represented by using the number of pieces of metal wires, used to create first, second and third patterns above.  
Write in terms of  $n$ , an expression for  $T_n$ , the number of pieces of metal wires used to create the  $n^{\text{th}}$  pattern, and there by find the number of pieces of metal wires used to create the  $8^{\text{th}}$  pattern.
  - Consider the number pattern which represents the number of nails used to create the above pattern and find the total number of nails that is required to create  $8^{\text{th}}$  patterns as give in the figures.
- b. Find the sum of the first 8th terms of the geometric progression  $\frac{3}{2}, 3, 6, 12, \dots$
- (08) Use only a straight edge with a cm/mm scale and a pair of compasses for the following constructions show the construction lines clearly.
- Construct the triangle ABC such that  $AB = 10\text{cm}$ ,  $AC = 9\text{cm}$  and  $\angle BAC = 75^\circ$
  - Construct the perpendicular bisector of AB and mark O as the point where the perpendicular bisector meets AB.
  - Construct the angle bisector of  $\angle BAC$ . Construct a circle, by taking the intersection point of the angle bisector and the perpendicular bisector drawn in (II) above, as the centre and touches the side AB at the point O.
  - Name the point which it touches the above circle and the side AC as P. Give reasons why  $AO = AP$
- (09)a. Himali has 8 identical solid glass balls with equal size and shape. She needs to find the radius of a glass ball. These eight glass balls are completely immersed in the water of a container, of the shape of a cuboid with length, breadth and height 11 cm, 8 cm and  $h$  respectively, and the height of the water level is  $\frac{2}{3}$  of it's total height.  $r = \frac{\sqrt{7h}}{2}$   
If the water of the container reaches the spilling level after immersion of the eight glass balls, then show that the radius of the glass ball.
- b. Taking that  $h = 12.5$  cm and using logarithmic tables, find the value  $r$  to the nearest first decimal place.

- (10) In the given figure  $ABXY$  and  $BCPQ$  are two rectangles.  $AB = 2 BC$ ,  $XQ = PQ$  and  $BX = 2BQ$ . Copy the figure into your answer script and include the above information in it. Prove that  $PX^2 + CY^2 = 10 BC^2 + 5 QX^2$

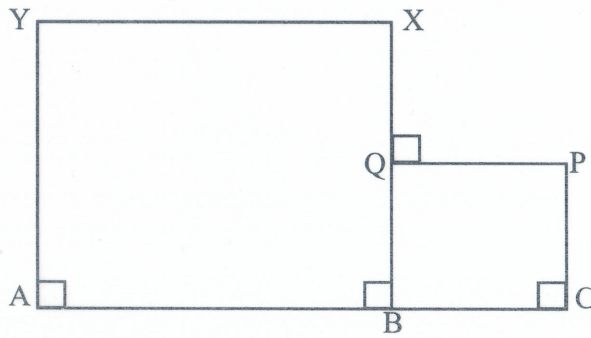

- (11) In the given figure, The points  $A, B, C$  and  $D$  lie on the circle with the centre  $O$ , such that  $DC \parallel AB$ . The line  $DC$  produced and the tangent drawn to the circle at  $B$ , meets at  $E$ . The lines  $AC$  and  $BD$  intersect at  $M$ .

- Show that  $\hat{ADB} = \hat{BEC}$
- Show that  $\triangle AMB$  is an isosceles triangle
- Prove that  $\triangle ABD \cong \triangle ABC$
- Give reasons as to why  $\hat{BCE} = \hat{BAD}$

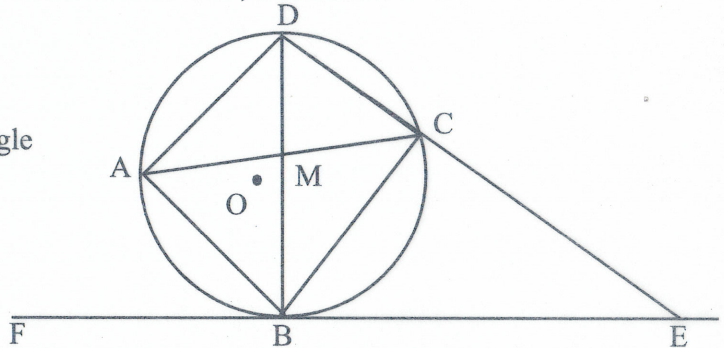

- (12) An incomplete Venn diagram drawn to represent information of the survey to have students in a hostel is shown here.

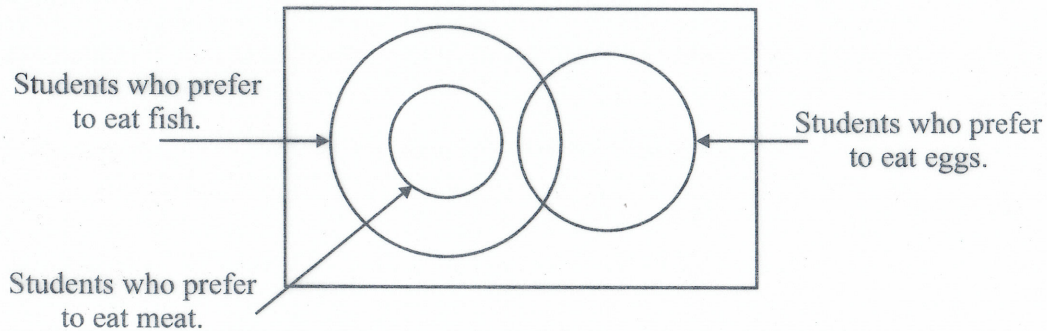

All the student who prefer to eat meat is also prefer to eat fish. Number of students who prefer to eat both fish and eggs is 6. Eight students do not prefer to eat either of the above item

- Copy the given Venn diagram in your answer script and include given information in it.
- Shade the region which represent the students who prefer to eat only two types of food items.
- If the students who prefer to eat egg is 15 and student who prefer to eat only one type of food item is 21, Calculate the number of students who do not prefer to eat meat.
- If 15 students prefer to eat meat, calculate the percentage of the students who do not prefer to eat fish, out of the total number of students.
- Later reveal that, out of the 15 students who prefer to eat meat 04 students prefer to eat eggs. Accordingly draw a new venn diagram according to the changed data and indicate the relevant data on the diagram.





### Third term test 2023(2024)

### Mathematics

### Answer sheet Paper I -Part-A

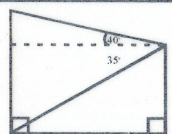
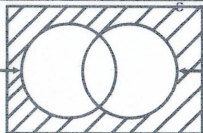
### Grade 11

Q.N	Answer	Marks	
01.	Interest for 2 years = Rs.6400 $\frac{50}{100} \times 40000 \times 2$	01	02
02.	Minimum length = 50 cm $2 \times \frac{22}{7} \times 7 \times \frac{1}{4}$ or 11+11+28	01	02
03.	i. $5^2 = x$ ii. $25 = x$	01 01	02
04.	$\frac{1}{3x^2}$ $\frac{3-2}{3x^2}$	01	02
05.	$\hat{PQS} = 135^\circ$ $\hat{PRQ} = 45^\circ$ or $\hat{PQR} = 45^\circ$	01	02
6.	$x = 11$ for $x+1 = 12$	01	02
07.	$3x^2 - 8x + 3x - 8$ $x(3x-2) + 1(3x-8)$ $(3x-8)(x+1)$	01 01	02
08.	$2 \times \frac{22}{7} \times r = 44$ $r = 7\text{cm}$	01 01	02
09.	 Mark $40^\circ$ and $35^\circ$ correctly Mark perpendicular and 50m	01 01	02
10.	Students who ate ice cream  Boys	02	
11.	$x = 7$ or $x = -7$ $x^2 = 49$ or $(x+7)(x-7)$	02	
12.	total number of cards = 27	02	
13.	$ABE \Delta \cong BDC \Delta$ SAS	01 01	02
14.	i. <input checked="" type="checkbox"/> ii. <input checked="" type="checkbox"/> iii. <input checked="" type="checkbox"/>	02	
15.	$12x^2y$	02	

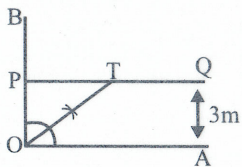
Q.N	Answer	Marks	
16.	To mark the top of the mid points of each columns To mark & join the mid points of the class intervals 5-10 and 30-35 and drawing accurate frequency polygon	01 01	02
17.	$x = 19\text{ cm}$ for $x+5 = 24$	01	02
18.	volume = $15.4 \times 200$ $= 3080\text{ cm}^3$	01 01	02
19.	$x \leq 3$ 	01 01	02
20.	$\hat{OCB} = 34^\circ$ $\hat{OBC} = 34^\circ$	01	02
21.	$40\text{ kmh}^{-1}$ $\frac{160 - 80}{6 - 4}$	01	02
22.	$x = 65^\circ$ $\hat{AEB} = 65^\circ$ or $\hat{BED} = 115^\circ$	01	02
23.	bisector of $\hat{AOB}$ to mark T 	01 01	02
24.	i. $m = 2$ ii. $y = 2x+1$	01 01	02
25.	i. $AB = 14\text{ cm}$ ii. $\hat{ADC} = 130^\circ$	01 01	02
Part - B			
01.	Who did not give contribution = $1 - \frac{1}{3}$ to repair play ground $= \frac{2}{3}$  Who participated to fix school fence $= \frac{2}{3} \times \frac{3}{5}$ $= \frac{2}{5}$	01  01	01

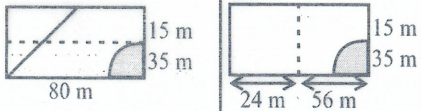
Q.N	Answer	Marks
02	Who participated to repair Grade 1 class room = $1 - \left(\frac{1}{3} + \frac{1}{3}\right)$	01
	= $1 - \left(\frac{5+6}{15}\right)$	
	= $1 - \frac{11}{15}$	01
	= $\frac{4}{15} \div 2$	
	= $\frac{4}{15} \times \frac{1}{2}$	
	= $\frac{2}{15}$	01 03
	Who participated to shramadana campaign = $\frac{2}{15} \rightarrow 6$	
	= $\frac{6}{2} \times 15$	01
	= <u>45</u>	
	Who participated to repair play ground = $45 \times \frac{1}{3}$	01
= 15	01	
Number of days = $\frac{30}{15}$	01 02	
= <u>2</u>		
<b>10</b>		
(02)	i. Land owned to daughter = $\frac{1}{2} \times 48 \times 50$	01
	= 1200 m <sup>2</sup>	01
	Land owned to son = $\frac{1}{2} \times 50 (80+32)$	01 04
	= 2800 m <sup>2</sup>	01
	ii. Daughter : Son = 1200:2800	
	3:7	02
	iii. Perimeter = $2 \times 22 \times 35 \times \frac{1}{4} + 70$	
	= 55 + 70	01 02
	= <u>125m</u>	
	iv. 	01
Breadth of Daughter's Land = $\frac{1200}{80}$		
= 15m	01	
= $\frac{1200}{50}$		
= 24m	01	
Breadth of Son's Land = $\frac{2800}{80}$		
= 35m or	01 02	
= $\frac{2800}{50}$		
= 56m		
<b>10</b>		

Q.N	Answer	Marks
(03)a.	i. No. of Shares sold from A = $\frac{60}{100} \times 200$	01
	= 120	01
	ii. No. of shares bought from B = 120 x 50	
	= $\frac{120 \times 50}{60}$	01
	= 100	01 02
	iii. Dividend income from A = 200 - 120	
	= Rs. 80	01
	= 80 x 8	01
	= Rs. 640	
	iv. Dividend income from B = 100 x 10	01
= 1000		
Total Dividend income = 1000 + 640		
= Rs. 1640	01 04	
b. Tax for initial 500 000 = $\frac{4}{100} \times 500 000$		
= 20000	01	
Tax for remaining 150 000 = $\frac{8}{100} \times 150 000$		
= 12000	01	
Total income tax = 20000 + 12000		
= <u>Rs. 32000</u>	01 03	
<b>10</b>		
(04)a.	i. Class Boundaries - 7.5 - 12.5	
	- 12.5 - 17.5	01
	Frequency Column } - 3	
	Cumulative Frequency } - 4	
	- 6	01 02
	ii. To correct axes	01
	To correct points	01
	Smooth Curve	01 03
	iii. To getting Q1	01
	To getting Q3	01
Interquartile range	01 03	
Central Angle = $\frac{360^\circ}{60} \times 10$		
= $\frac{60^\circ}{60}$	01	
= <u>60^\circ</u>	01 02	
<b>10</b>		





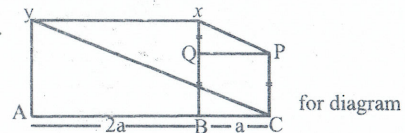

Q.N	Answer	Marks
(07) b.	$S_n = \frac{a(f^n - 1)}{f - 1}$ $= \frac{3}{2} \frac{(2^8 - 1)}{2 - 1}$ $= \frac{3}{2} (256 - 1)$ $= \frac{3}{2} \times 255$ $= \underline{\underline{382 \frac{1}{2}}}$	01 01 01 03 10
(08)	i. constructing $\widehat{A} = 10^\circ$ constructing $\widehat{BAC} = 75^\circ$ AC = 9 cm constructing the triangle ABC 01 01 01 03 ii. constructing the perpendicular bisector of AB. Marking O 01 03 iii. constructing the angle bisector of $\widehat{BAC}$ constructing the circle 01 01 02 iv. Marking P Tangents drawn from the same external point are equal in length 01 02 10	01 01 01 03 01 01 02 01 02 10
(09) a.	Volume of cuboid = $11 \times 8 \times h$ volume of 8 glass balls = $\frac{4}{3} \times \frac{22}{7} \times r^3 \times 8$ $\frac{1}{3} \times 11 \times 8 \times h = \frac{4}{3} \times \frac{22}{7} \times r^3 \times 8$ $\frac{11 \times 8 \times h \times 3 \times 7}{3 \times 4 \times 22 \times 8} = r^3$ $\frac{\sqrt[7]{7h}}{8} = r^3$ $\frac{\sqrt[7]{7h}}{2} = r^3$ $r = \sqrt[3]{\frac{\sqrt[7]{7 \times 12.5}}{2}}$ $r = \left( \frac{1}{3} \lg 7 + \frac{1}{3} \lg 12.5 \right) \div \lg 2$ $= \left( \frac{1}{3} \times 0.8451 + \frac{1}{3} \times 1.0969 \right) \div 0.3010$ $= (0.2817 + 0.3656) \div 0.3010$ $= 0.6473 \div 0.3010$ $= 0.3463$ $= \text{antilog } 0.3463$ $r = 2.22$	01 01 01 01 04 01 03 01 01 06 10
(10)	i.  for diagram Data :- ABXY and BCP are two rectangles XQ = PC and AB = 2 BC. to prove that :- $Px^2 + Cy^2 = 10BC^2 + 5Qx^2$ construction :- join Px and Cy	01 01 01 06 10

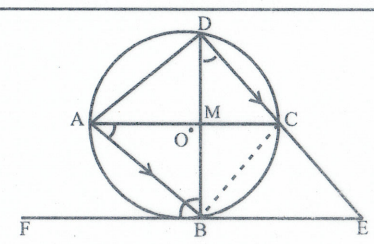
Grade 11 Mathematics - Paper II		
Q.N	Answer	Marks
	proof :-  PQx $\Delta$ Pythagoras Relation $Px^2 = Qx^2 + PQ^2$ PQ = BC (opposite sides of the rectangle BCPO)  $\therefore Px^2 = Qx^2 + BC^2$ $Qx = BQ$ (data) $\therefore Bx = 2Qx$ $Bx = Ay$ (opposite sides of the rectangle ABxy) $\therefore Ay = 2Qx$ AB = 2BC (data) $\therefore AC = 3BC$ .  ACy $\Delta$ Pythagoras Relation $C^2 = Ay^2 + AC^2$ $yC^2 = (2Qx)^2 + (3BC)^2$ $yC^2 = 4Qx^2 + 9BC^2$ $Px^2 + yC^2 = 5Qx^2 + 10BC^2$	01 01 01 01 01 01 01 10
(11)	 data :- The points A, B, C, and D lie on the circle with the centre O. (DC//AB) the tangent drawn to the circle at the point B is FE. i. To prove that :- $\widehat{ADB} = \widehat{BEC}$ Proof :- $\widehat{ADB} = \widehat{ABF}$ (angles in the alternate segment) $\widehat{BEC} = \widehat{ABF}$ ( $\widehat{A}/\widehat{D}$ ) $\therefore \widehat{ADB} = \widehat{BEC}$ ii. To prove that :- AMB is an isosceles triangle Proof :- $\widehat{AMB} = \widehat{BDC}$ ( $\widehat{A}/\widehat{D}$ ) $\widehat{BAM} = \widehat{BDC}$ (angles in the same segment) $\therefore \widehat{AMB} = \widehat{BAM}$ $\therefore AM = BM$ $\therefore$ AMB is an isosceles triangle iii. To prove that $\widehat{ABD} \Delta \equiv \widehat{ABC} \Delta$ Proof :- $\widehat{ABD} \Delta \equiv \widehat{ABC} \Delta$ $\widehat{ABD} = \widehat{BAC}$ (Proved) $\widehat{ADB} = \widehat{ACB}$ (angles in the same segment) AB = AB (Common) $\therefore \widehat{ABD} \Delta \equiv \widehat{ABC} \Delta$ (A.A.S.) iv. In a cyclic quadrilateral exterior angle is equal to the interior opposite angle	01 01 01 01 01 01 01 01 01 01 01 01 01 01 01 01 01 01 01 10

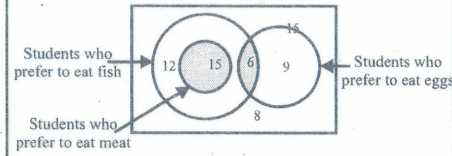
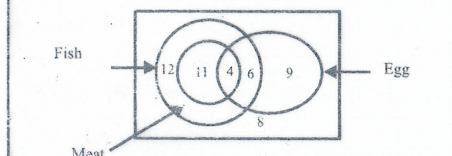
Q.N	Answer	Marks
(12)	<p>i.</p>  <p>Students who prefer to eat fish → 12          Students who prefer to eat eggs ← 9          Students who prefer to eat meat → 8</p> <p>Marking 6 and 8</p> <p>ii. Shading the correct region</p> <p>iii. Marking 9 and 12          not eating meats = <math>12+8+6+9</math>  <math>= 35</math></p> <p>iv. Total = <math>35+15</math>  <math>= 56</math>          Not eating fish = <math>9+8</math>  <math>= 17</math>          Percentage = <math>\frac{17}{56} \times 100</math>  <math>= 34\%</math></p>  <p>Fish → 12          Egg ← 9          Meat → 8</p> <p>Drawing the correct venn diagram          Marking 11 and 4</p>	<p>02 02</p> <p>02 02</p> <p>01</p> <p>01 02</p> <p>01</p> <p>01 02</p> <p>01</p> <p>01 02</p> <p>01</p> <p>01 02</p> <p>01 02</p> <p>01 02</p> <p>01 02</p> <p>01 02</p> <p>01 02</p>
		<u>10</u>





LOL.lk  
BookStore

විභාග ඉලක්ක

පහසුවෙන් ජයගන්න

ඕනෑම පොතක් ඉක්මනින්  
නිවසටම ගෙන්වා ගන්න



| කෙටි සටහන් | පසුගිය ප්‍රශ්න පත්‍ර | වැඩ පොත් | සඟරා | O/L ප්‍රශ්න පත්‍ර  
| A/L ප්‍රශ්න පත්‍ර | අනුමාන ප්‍රශ්න පත්‍ර | අතිරේක කියවීම් පොත්  
| School Book | ගුරු අත්පොත්



pesuru  
Prabhathana Private Ltd.

Akura Pilot

සමනල  
දැනුම

T

සුභාර

පෙර පාසලේ සිට උසස් පෙළ දක්වා සියලුම ප්‍රශ්න පත්‍ර,  
කෙටි සටහන්, වැඩ පොත්, අතිරේක කියවීම් පොත්, සඟරා  
සිංහල සහ ඉංග්‍රීසි මාධ්‍යයෙන් ගෙදරටම ගෙන්වා ගැනීමට

www.LOL.lk වෙබ් අඩවිය වෙත යන්න